

| REVISION HISTORY | | APPROVED | DATE |
|------------------|-----------------|----------|------------|
| REV | DESCRIPTION | J Taylor | 2025/11/13 |
| - | Initial release | | |

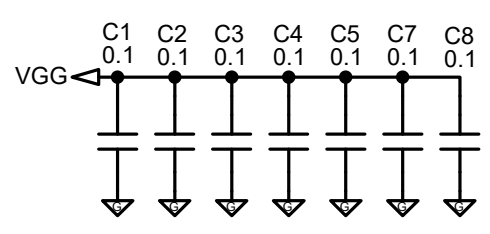

| APPROVALS | | DATE | TITLE |
|---------------|----------|------------|--|
| DRAWN | J TAYLOR | 2022/11/03 | 24K SRAM module for TRS80 PC2 |
| CHECKED | | | |
| ENGINEER | | | |
| PROJ ENGINEER | | | SIZE FSCM NO. DRAWING NO. 1714 |
| APPROVED | | | REV. - |
| QA | | | SCALE NONE © 2023 TES MODIFIED: 12/10/2025 3:27:56 PM SHEET 1 OF 2 |

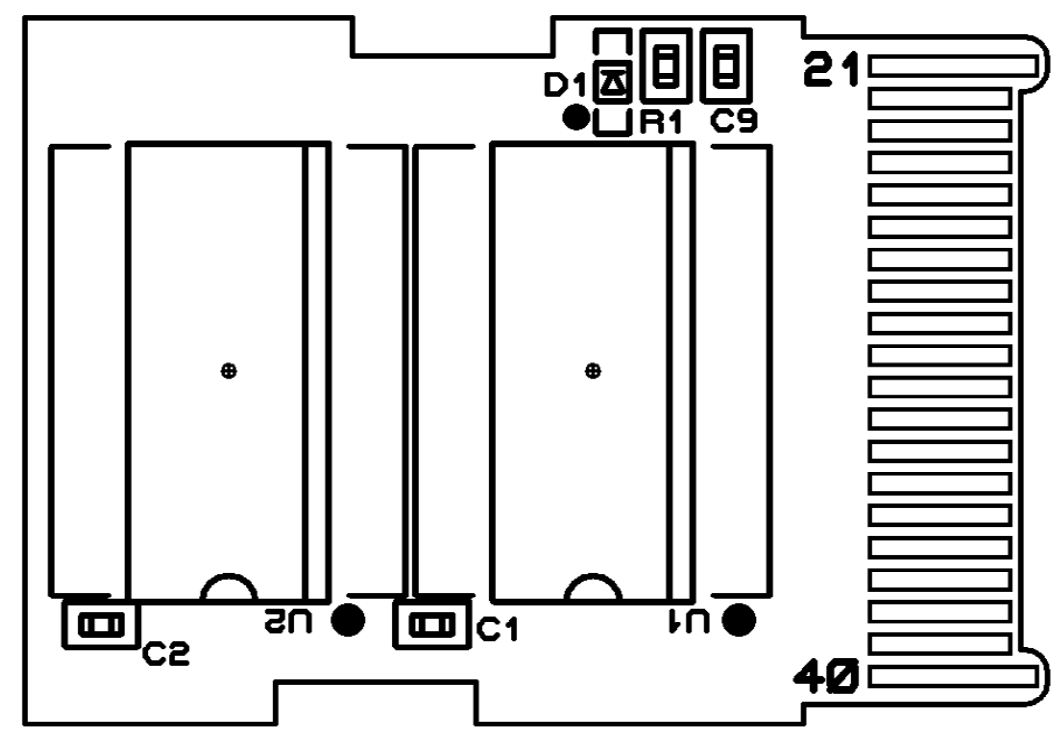
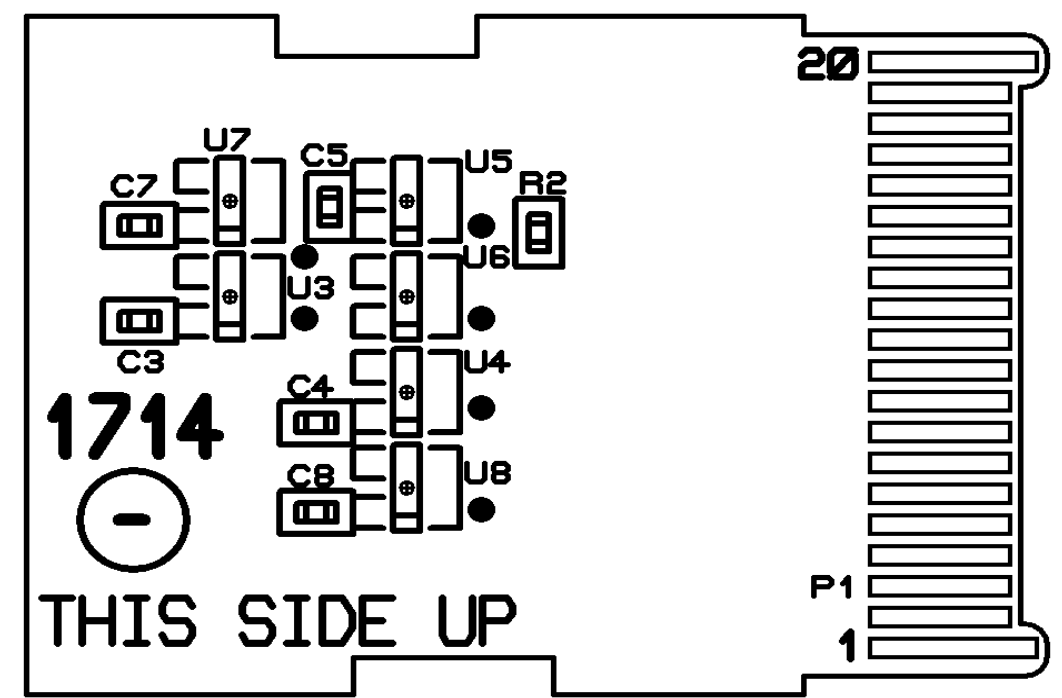
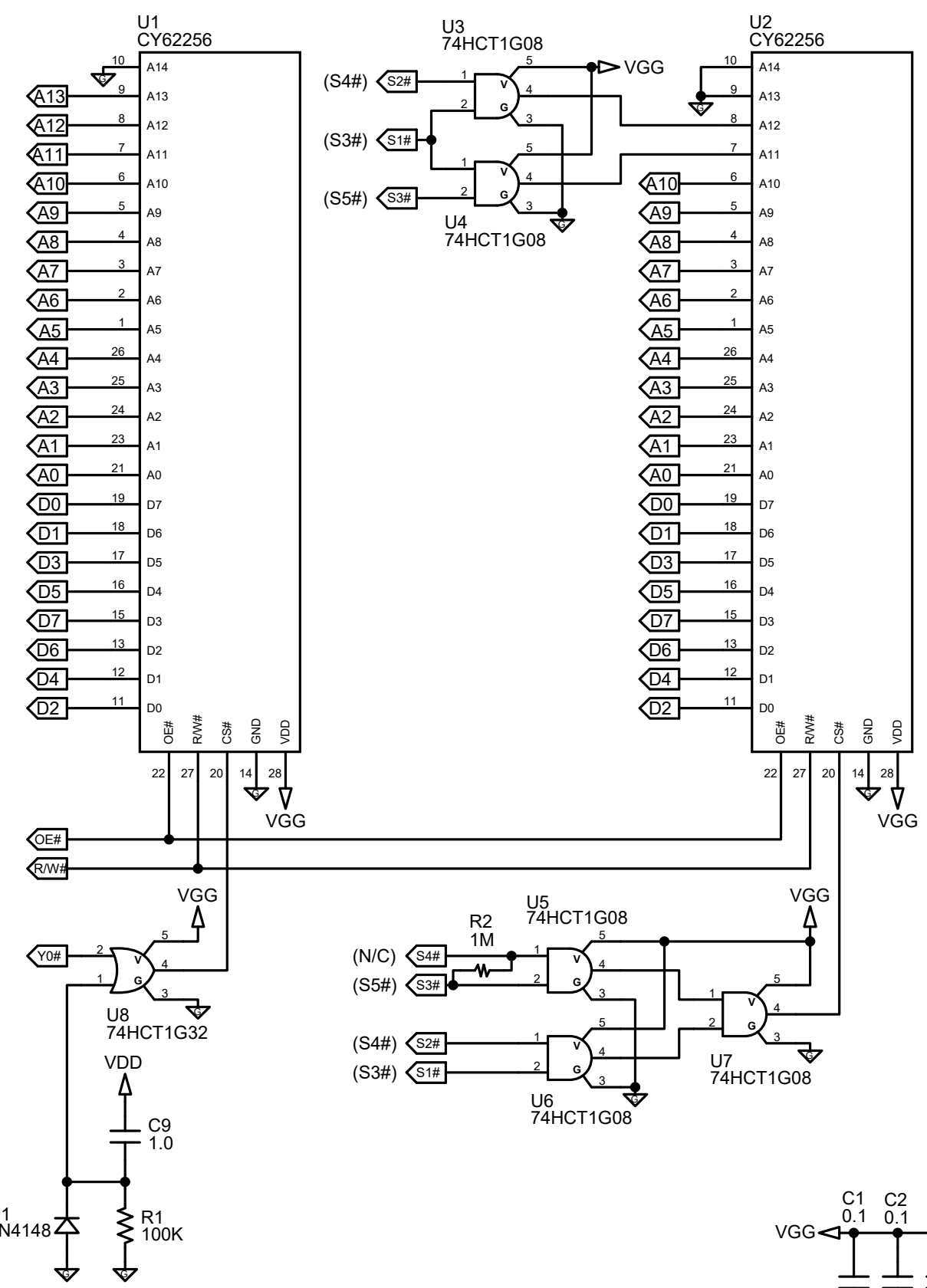
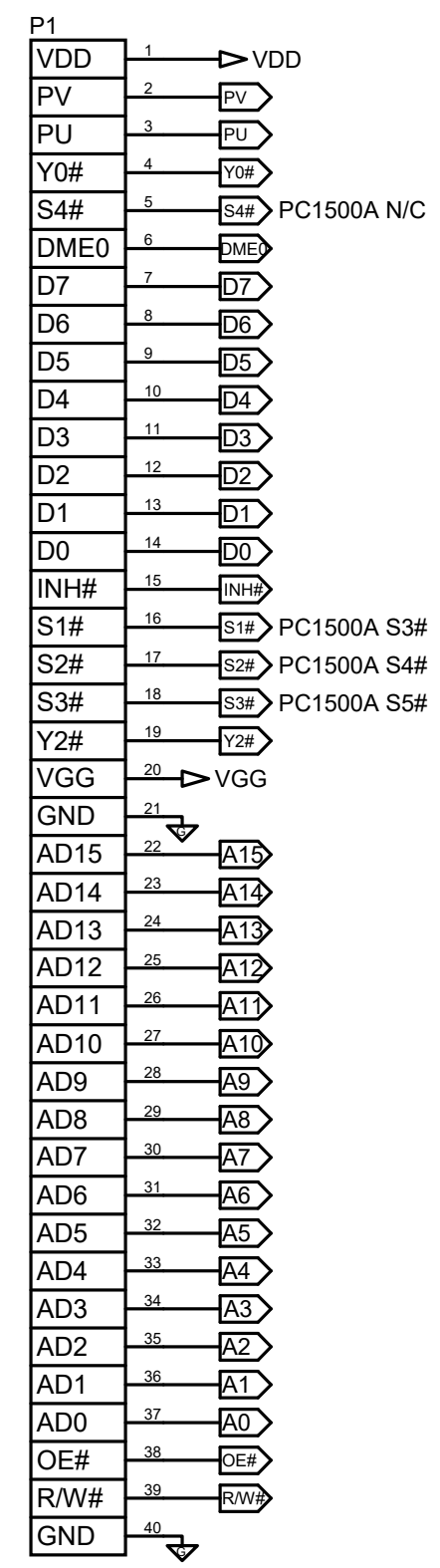