

REVISION HISTORY			
REV	DESCRIPTION	APPROVED	DATE

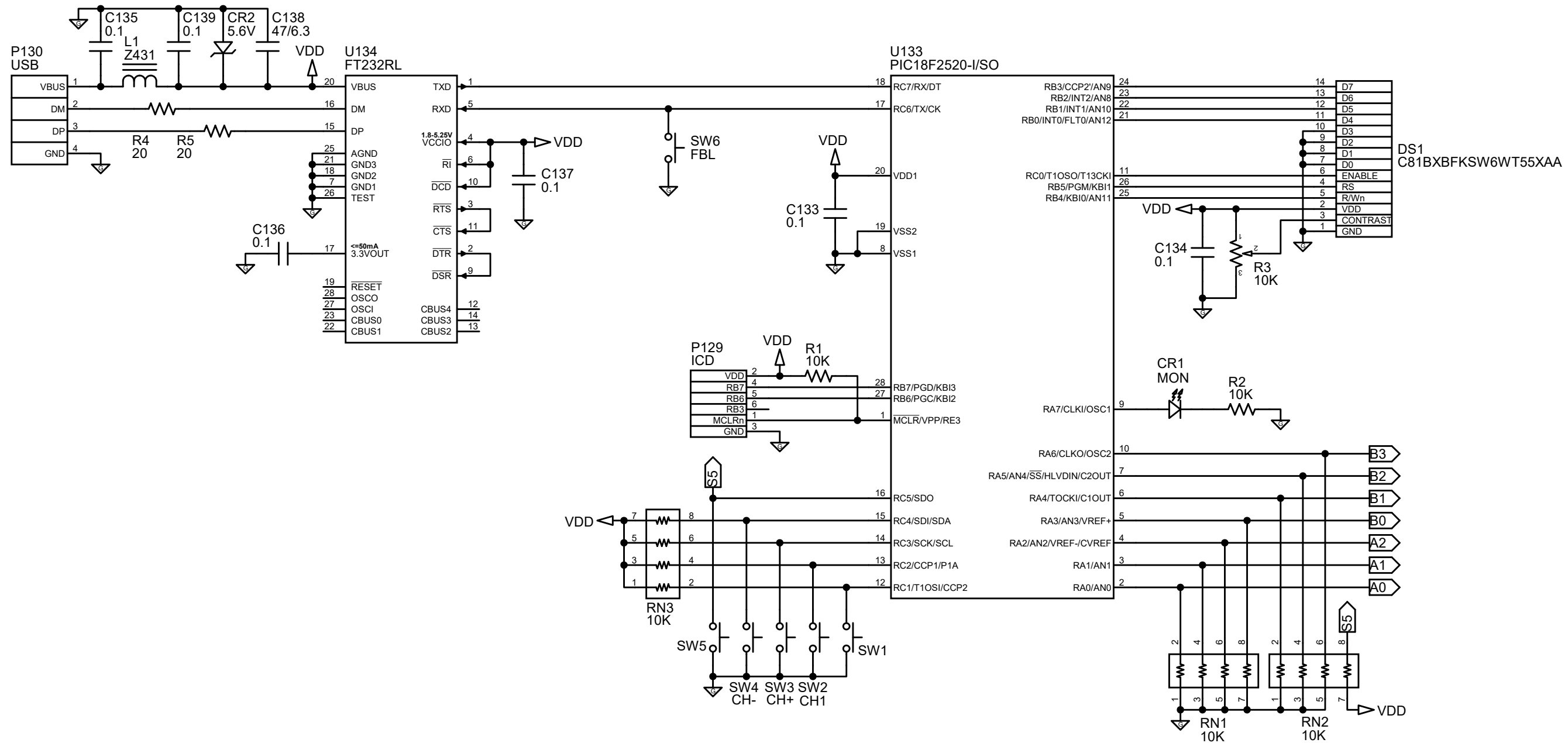

APPROVALS		DATE	TITLE	
DRAWN	J TAYLOR	04/29/14	128 channel mux (32bank x 4ch) FW: 022201RR	
CHECKED				
ENGINEER				
PROJ ENGINEER			SIZE	FSCM NO.
APPROVED			B	DRAWING NO. 1498
QA			SCALE	NONE
			© 2020 TES	MODIFIED: 12/19/20 10:46:26 AM
			SHEET	1 OF 6

REVISION HISTORY			
REV	DESCRIPTION	APPROVED	DATE

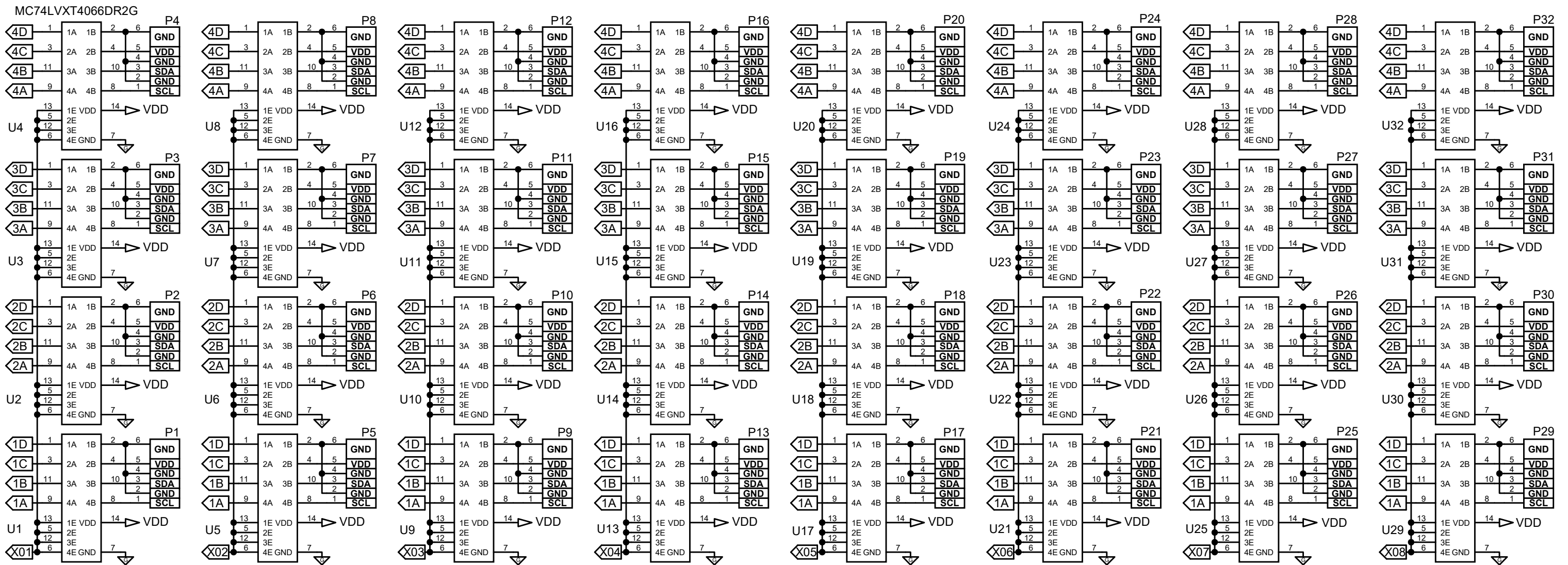

These are the common I/O connections

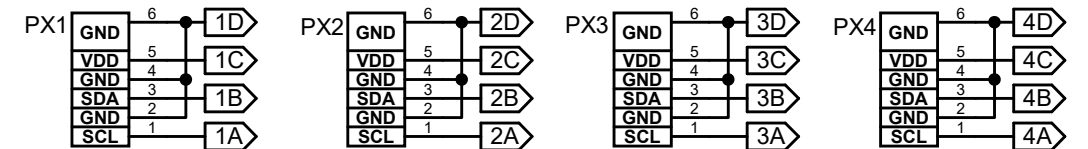
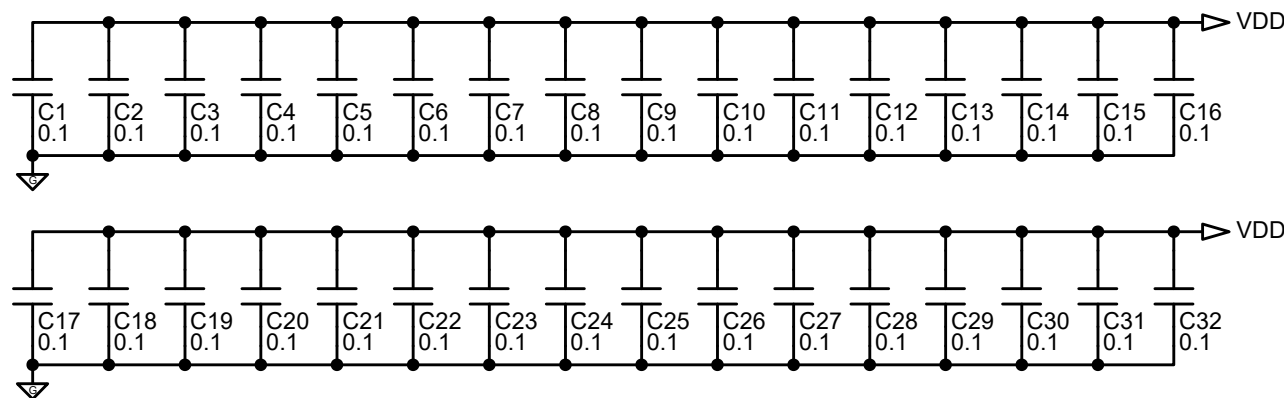
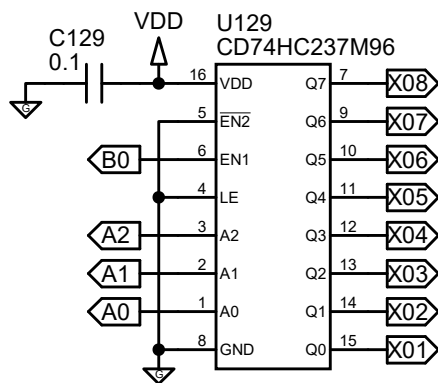

APPROVALS		DATE	TITLE
DRAWN	J TAYLOR	04/29/14	128 channel mux (32bank x 4ch) FW: 022201RR
CHECKED			
ENGINEER			
PROJ ENGINEER			SIZE FSCM NO. DRAWING NO. 1498
APPROVED			REV. -
QA			SCALE NONE © 2020 TES MODIFIED: 12/19/20 10:46:26 AM SHEET 2 OF 6

REVISION HISTORY			
REV	DESCRIPTION	APPROVED	DATE

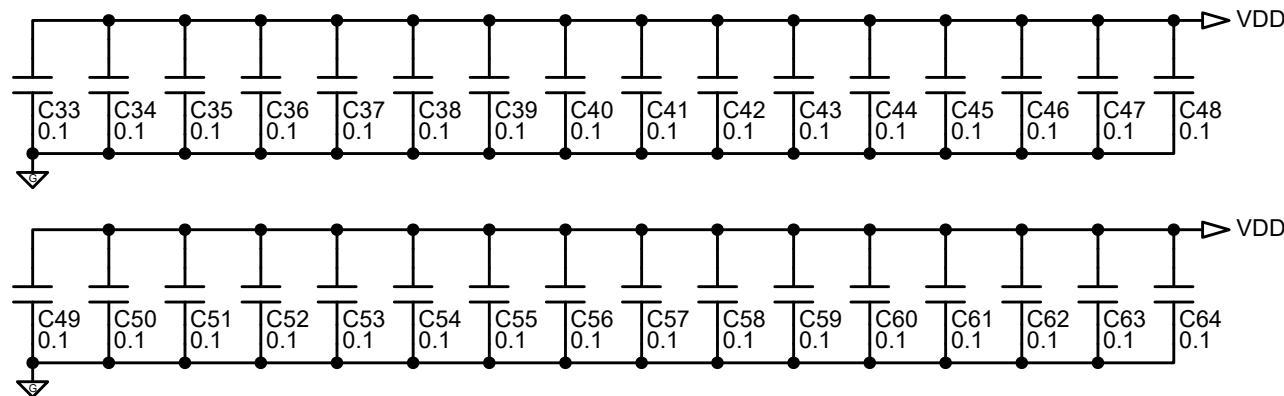
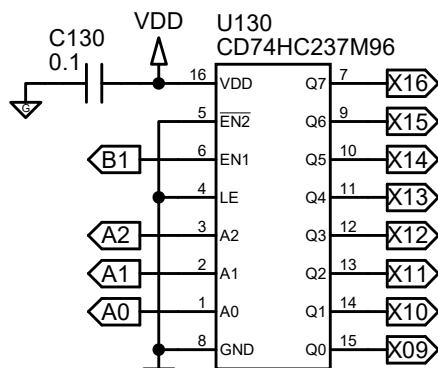
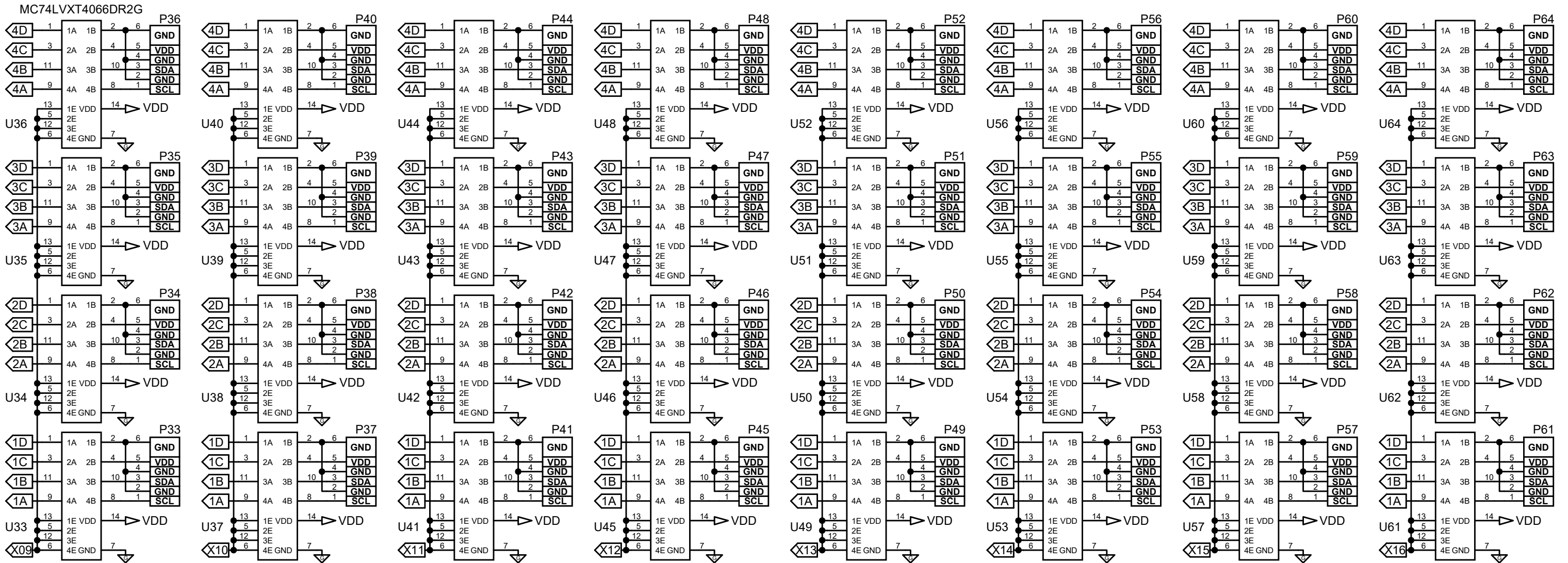

APPROVALS		DATE	TITLE	
DRAWN	J TAYLOR	04/29/14	128 channel mux (32bank x 4ch)	
CHECKED			FW: 022201RR	
ENGINEER			SIZE	FSCM NO.
PROJ ENGINEER			DRAWING NO. 1498	
APPROVED			SCALE	NONE
QA			© 2020 TES	MODIFIED: 12/19/20 10:46:26 AM
SHEET 3 OF 6			REV. -	

NOTES: UNLESS OTHERWISE SPECIFIED

REVISION HISTORY			
REV	DESCRIPTION	APPROVED	DATE

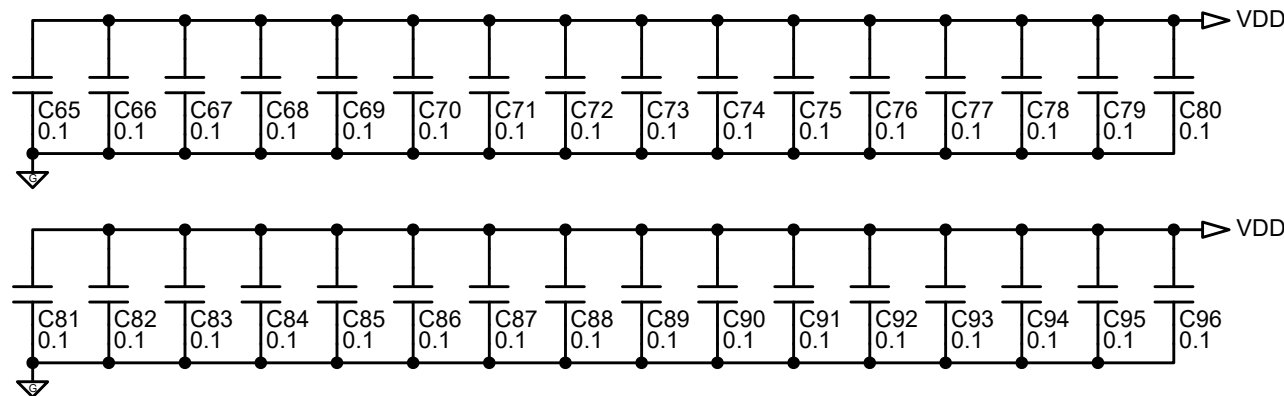
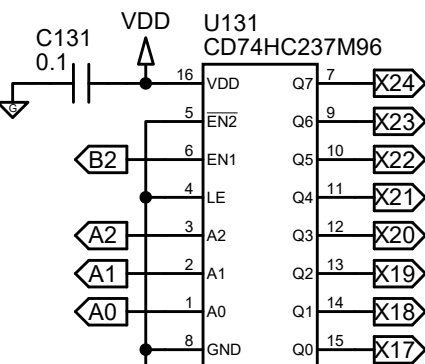
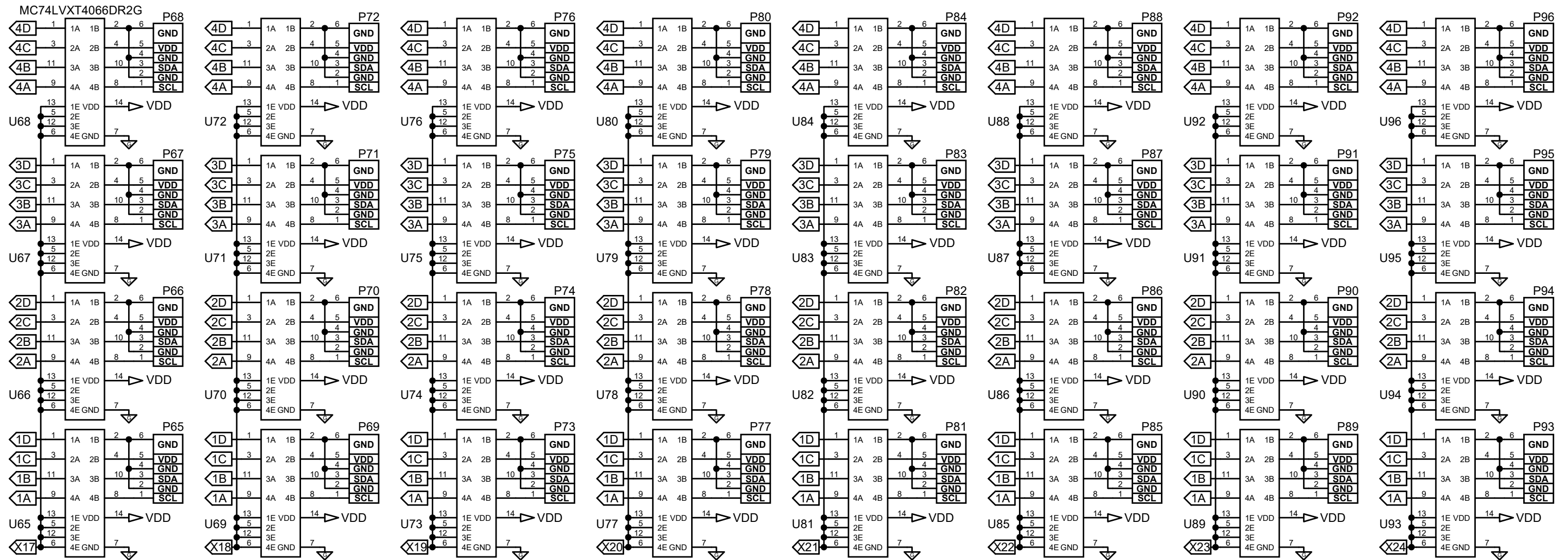

APPROVALS		DATE	TITLE
DRAWN	J TAYLOR	04/29/14	128 channel mux (32bank x 4ch) FW: 022201RR
CHECKED			
ENGINEER			
PROJ ENGINEER			SIZE FSCM NO. DRAWING NO. 1498
APPROVED			REV. -
QA			SCALE NONE © 2020 TES MODIFIED: 12/19/20 10:46:26 AM SHEET 4 OF 6

NOTES: UNLESS OTHERWISE SPECIFIED

REVISION HISTORY			
REV	DESCRIPTION	APPROVED	DATE

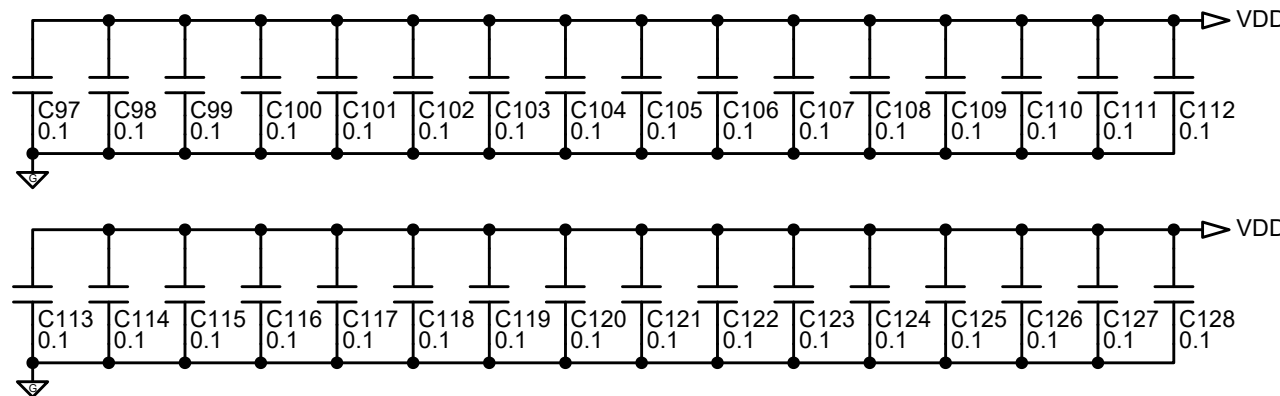
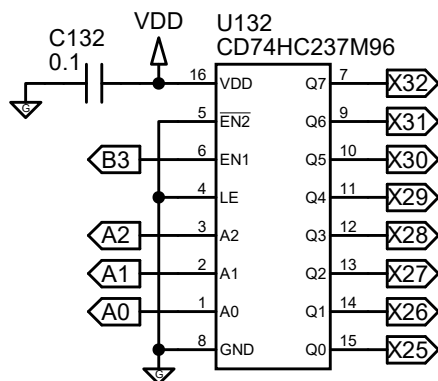
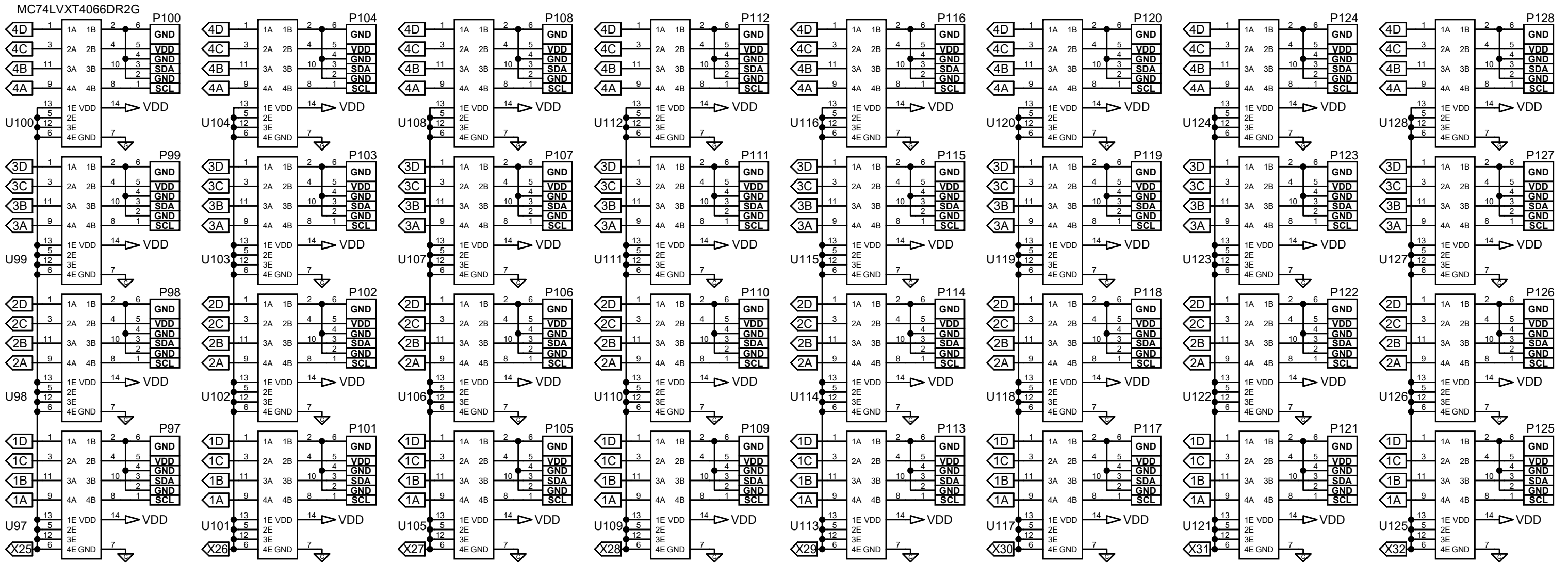

APPROVALS		DATE	TITLE	
DRAWN	J TAYLOR	04/29/14	128 channel mux (32bank x 4ch) FW: 022201RR	
CHECKED			SIZE	FSCM NO.
ENGINEER			DRAWING NO. 1498	
PROJ ENGINEER			SCALE	REV. -
APPROVED			NONE	
QA			© 2020 TES	MODIFIED: 12/19/20 10:46:26 AM
			SHEET	5 OF 6

REVISION HISTORY			
REV	DESCRIPTION	APPROVED	DATE

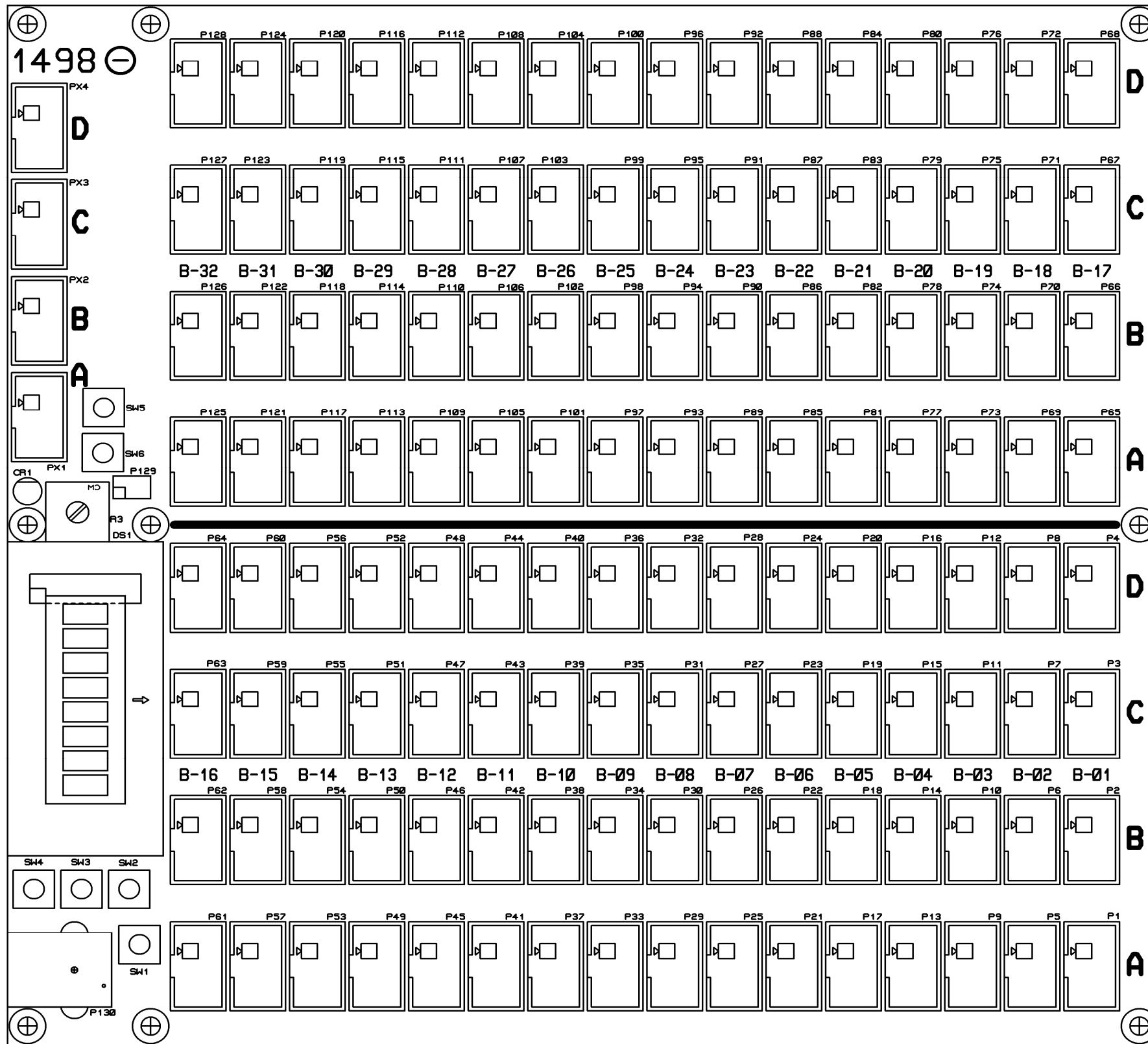

APPROVALS		DATE	TITLE	
DRAWN	J TAYLOR	04/29/14	128 channel mux (32bank x 4ch)	
CHECKED			FW: 022201RR	
ENGINEER			SIZE	FSCM NO.
PROJ ENGINEER			B	DRAWING NO. 1498
APPROVED			SCALE	NONE
QA			© 2020 TES	MODIFIED: 12/19/20 10:46:26 AM
			SHEET	6 OF 6
			REV.	-