



RN4020 Bluetooth[®] Low Energy Module User's Guide

Note the following details of the code protection feature on Microchip devices:

- Microchip products meet the specification contained in their particular Microchip Data Sheet.
- Microchip believes that its family of products is one of the most secure families of its kind on the market today, when used in the intended manner and under normal conditions.
- There are dishonest and possibly illegal methods used to breach the code protection feature. All of these methods, to our knowledge, require using the Microchip products in a manner outside the operating specifications contained in Microchip's Data Sheets. Most likely, the person doing so is engaged in theft of intellectual property.
- Microchip is willing to work with the customer who is concerned about the integrity of their code.
- Neither Microchip nor any other semiconductor manufacturer can guarantee the security of their code. Code protection does not mean that we are guaranteeing the product as "unbreakable."

Code protection is constantly evolving. We at Microchip are committed to continuously improving the code protection features of our products. Attempts to break Microchip's code protection feature may be a violation of the Digital Millennium Copyright Act. If such acts allow unauthorized access to your software or other copyrighted work, you may have a right to sue for relief under that Act.

Information contained in this publication regarding device applications and the like is provided only for your convenience and may be superseded by updates. It is your responsibility to ensure that your application meets with your specifications. MICROCHIP MAKES NO REPRESENTATIONS OR WARRANTIES OF ANY KIND WHETHER EXPRESS OR IMPLIED, WRITTEN OR ORAL, STATUTORY OR OTHERWISE, RELATED TO THE INFORMATION, INCLUDING BUT NOT LIMITED TO ITS CONDITION, QUALITY, PERFORMANCE, MERCHANTABILITY OR FITNESS FOR PURPOSE. Microchip disclaims all liability arising from this information and its use. Use of Microchip devices in life support and/or safety applications is entirely at the buyer's risk, and the buyer agrees to defend, indemnify and hold harmless Microchip from any and all damages, claims, suits, or expenses resulting from such use. No licenses are conveyed, implicitly or otherwise, under any Microchip intellectual property rights.

Trademarks

The Microchip name and logo, the Microchip logo, dsPIC, FlashFlex, KEELOQ, KEELOQ logo, MPLAB, PIC, PICmicro, PICSTART, PIC³² logo, rPIC, SST, SST Logo, SuperFlash and UNI/O are registered trademarks of Microchip Technology Incorporated in the U.S.A. and other countries.

FilterLab, Hampshire, HI-TECH C, Linear Active Thermistor, MTP, SEEVAL and The Embedded Control Solutions Company are registered trademarks of Microchip Technology Incorporated in the U.S.A.

Silicon Storage Technology is a registered trademark of Microchip Technology Inc. in other countries.

Analog-for-the-Digital Age, Application Maestro, BodyCom, chipKIT, chipKIT logo, CodeGuard, dsPICDEM, dsPICDEM.net, dsPICworks, dsSPEAK, ECAN, ECONOMONITOR, FanSense, HI-TIDE, In-Circuit Serial Programming, ICSP, Mindi, MiWi, MPASM, MPF, MPLAB Certified logo, MPLIB, MPLINK, mTouch, Omniscient Code Generation, PICC, PICC-18, PICDEM, PICDEM.net, PICkit, PICtail, REAL ICE, rLAB, Select Mode, SQI, Serial Quad I/O, Total Endurance, TSHARC, UniWinDriver, WiperLock, ZENA and Z-Scale are trademarks of Microchip Technology Incorporated in the U.S.A. and other countries.

SQTP is a service mark of Microchip Technology Incorporated in the U.S.A.

GestIC and ULPP are registered trademarks of Microchip Technology Germany II GmbH & Co. KG, a subsidiary of Microchip Technology Inc., in other countries.

All other trademarks mentioned herein are property of their respective companies.

© 2014, Microchip Technology Incorporated, Printed in the U.S.A., All Rights Reserved.

 Printed on recycled paper.

ISBN: 978-1-63276-306-8

**QUALITY MANAGEMENT SYSTEM
CERTIFIED BY DNV
= ISO/TS 16949 =**

Microchip received ISO/TS-16949:2009 certification for its worldwide headquarters, design and wafer fabrication facilities in Chandler and Tempe, Arizona; Gresham, Oregon and design centers in California and India. The Company's quality system processes and procedures are for its PIC[®] MCUs and dsPIC[®] DSCs, KEELOQ[®] code hopping devices, Serial EEPROMs, microperipherals, nonvolatile memory and analog products. In addition, Microchip's quality system for the design and manufacture of development systems is ISO 9001:2000 certified.

Object of Declaration: RN4020 Bluetooth® Low Energy Module

EU Declaration of Conformity

This declaration of conformity is issued by the manufacturer.

The development/evaluation tool is designed to be used for research and development in a laboratory environment. This development/evaluation tool is not a Finished Appliance, nor is it intended for incorporation into Finished Appliances that are made commercially available as single functional units to end users under EU EMC Directive 2004/108/EC and as supported by the European Commission's Guide for the EMC Directive 2004/108/EC (8th February 2010).

This development/evaluation tool complies with EU RoHS2 Directive 2011/65/EU.

For information regarding the exclusive, limited warranties applicable to Microchip products, please see Microchip's standard terms and conditions of sale, which are printed on our sales documentation and available at www.microchip.com.

Signed for and on behalf of Microchip Technology Inc. at Chandler, Arizona, USA

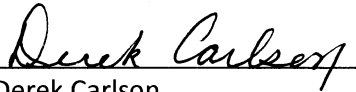

Derek Carlson

VP Development Tools

16-July-2013

Date

RN4020 Bluetooth Low Energy Module User's Guide

NOTES:



RN4020 BLUETOOTH LOW ENERGY MODULE USER'S GUIDE

Table of Contents

Preface	7
Chapter 1. Introduction	
1.1 Bluetooth Low Energy Fundamentals	13
Chapter 2. RN4020 OEM Module Interface	
2.1 RN4020 Control Lines	15
2.2 RN4020 UART Control Interface	19
2.3 Device Firmware Upgrade	59
Chapter 3. Application Examples	
3.1 Demonstration with a Smart Device	61
3.2 Connecting Two RN4020 Modules	71
3.3 MLDP Demonstration	74
3.4 RN4020 Scripting Demonstration	75
Appendix A. PICtail™ Daughter Board Schematics	77
Worldwide Sales and Service	84

NOTES:



RN4020 BLUETOOTH LOW ENERGY MODULE USER'S GUIDE

Preface

NOTICE TO CUSTOMERS

All documentation becomes dated, and this manual is no exception. Microchip tools and documentation are constantly evolving to meet customer needs, so some actual dialogs and/or tool descriptions may differ from those in this document. Please refer to our web site (www.microchip.com) to obtain the latest documentation available.

Documents are identified with a “DS” number. This number is located on the bottom of each page, in front of the page number. The numbering convention for the DS number is “DSXXXXXXXXA”, where “XXXXXXXX” is the document number and “A” is the revision level of the document.

For the most up-to-date information on development tools, see the MPLAB® IDE online help. Select the Help menu, and then Topics to open a list of available online help files.

INTRODUCTION

This chapter contains general information that will be useful to know before using the RN4020 Bluetooth® Low Energy Module. Items discussed in this chapter include:

- [Document Layout](#)
- [Conventions Used in this Guide](#)
- [Recommended Reading](#)
- [The Microchip Web Site](#)
- [Development Systems Customer Change Notification Service](#)
- [Customer Support](#)
- [Document Revision History](#)

DOCUMENT LAYOUT

This document describes how to use the RN4020 Bluetooth® Low Energy Module as a development tool to emulate and debug firmware on a target board. This document includes the following chapters:

- **Chapter 1. “Introduction”** provides a brief overview of the RN4020, highlighting its features and uses.
- **Chapter 2. “RN4020 OEM Module Interface”** provides information on the module interface.
- **Chapter 3. “Application Examples”** provides application examples that emphasize the features of the RN4020.
- **Appendix A. “PICtail™ Daughter Board Schematics”** provides schematic diagram information for the PICtail Daughter Board.

RN4020 Bluetooth Low Energy Module User's Guide

CONVENTIONS USED IN THIS GUIDE

This manual uses the following documentation conventions:

DOCUMENTATION CONVENTIONS

Description	Represents	Examples
Italic characters	Referenced books	<i>MPLAB[®] IDE User's Guide</i>
	Emphasized text	...is the <i>only</i> compiler...
Initial caps	A window	the Output window
	A dialog	the Settings dialog
	A menu selection	select Enable Programmer
Quotes	A field name in a window or dialog	"Save project before build"
Underlined, italic text with right angle bracket	A menu path	<u><i>File</i></u> > <u><i>Save</i></u>
Bold characters	A dialog button	Click OK
	A tab	Click the Power tab
Text in angle brackets < >	A key on the keyboard	Press <Enter>, <F1>
Plain Courier New	Sample source code	#define START
	Filenames	autoexec.bat
	File paths	c:\mcc18\h
	Keywords	_asm, _endasm, static
	Command-line options	-Opa+, -Opa-
	Bit values	0, 1
	Constants	0xFF, 'A'
<i>Italic Courier New</i>	A variable argument	<i>file.o</i> , where <i>file</i> can be any valid filename
Square brackets []	Optional arguments	mcc18 [options] <i>file</i> [options]
Curly brackets and pipe character: { }	Choice of mutually exclusive arguments; an OR selection	errorlevel {0 1}
Ellipses...	Replaces repeated text	var_name [, var_name...]
	Represents code supplied by user	void main (void) { ... }
Notes	A Note presents information that we want to re-emphasize, either to help you avoid a common pitfall or to make you aware of operating differences between some device family members. A Note can be in a box, or when used in a table or figure, it is located at the bottom of the table or figure.	<div style="border: 1px solid black; padding: 5px; margin-bottom: 5px;"> <p>Note: This is a standard note box.</p> </div> <div style="border: 1px solid black; padding: 5px; margin-bottom: 5px;"> <p style="text-align: center;">CAUTION</p> <p>This is a caution note.</p> </div> <p>Note 1: This is a note used in a table.</p>

RECOMMENDED READING

The following documents are recommended as supplemental reference resources.

RN4020 Family Data Sheet (DS50002279)

Consult this document for detailed information on the RN4020 Bluetooth® Low Energy Module. Reference information found in this data sheet includes:

- Device pinout and packaging details
- Device electrical specifications
- List of features included on the device

This document is available for download from the Microchip website (www.microchip.com).

Bluetooth Core Specification v4.0, 30 June 2010

This specification is available for download from www.bluetooth.org.

Bluetooth Core Specification v4.1, 3 December 2013

Bluetooth® Core Specification 4.1 is an important evolutionary update to the Bluetooth Core Specification. It rolls up adopted Bluetooth Core Specification Addenda (CSA 1, 2, 3, and 4) while adding new features and benefits. Bluetooth 4.1 improves usability for consumers, empowers innovation for product developers, and extends the technology's foundation as an essential link for the Internet of Things.

This specification is available for download from www.bluetooth.org.

RN4020 Bluetooth Low Energy Module User's Guide

THE MICROCHIP WEB SITE

Microchip provides online support via our web site at: <http://www.microchip.com>. This web site makes files and information easily available to customers. Accessible by most Internet browsers, the web site contains the following information:

- **Product Support** – Data sheets and errata, application notes and sample programs, design resources, user's guides and hardware support documents, latest software releases and archived software
- **General Technical Support** – Frequently Asked Questions (FAQs), technical support requests, online discussion groups, Microchip consultant program member listings
- **Business of Microchip** – Product selector and ordering guides, latest Microchip press releases, listings of seminars and events; and listings of Microchip sales offices, distributors and factory representatives

DEVELOPMENT SYSTEMS CUSTOMER CHANGE NOTIFICATION SERVICE

Microchip's customer notification service helps keep customers current on Microchip products. Subscribers will receive e-mail notification whenever there are changes, updates, revisions or errata related to a specified product family or development tool of interest.

To register, access the Microchip web site at www.microchip.com, click on Customer Change Notification and follow the registration instructions.

The Development Systems product group categories are:

- **Compilers** – The latest information on Microchip C compilers and other language tools
- **Emulators** – The latest information on the Microchip in-circuit emulator, MPLAB[®] REAL ICE[™]
- **In-Circuit Debuggers** – The latest information on the Microchip in-circuit debugger, MPLAB ICD 3
- **MPLAB X IDE** – The latest information on Microchip MPLAB X IDE, the Windows[®] Integrated Development Environment for development systems tools
- **Programmers** – The latest information on Microchip programmers including the PICkit[™] 3 development programmer

CUSTOMER SUPPORT

Users of Microchip products can receive assistance through several channels:

- Distributor or Representative
- Local Sales Office
- Field Application Engineer (FAE)
- Technical Support

Customers should contact their distributor, representative or field application engineer (FAE) for support. Local sales offices are also available to help customers. A listing of sales offices and locations is included in the back of this document.

Technical support is available through the web site at: <http://support.microchip.com>

DOCUMENT REVISION HISTORY

Revision A (June 2014)

Initial release of this document.

RN4020 Bluetooth Low Energy Module User's Guide

NOTES:



RN4020 BLUETOOTH LOW ENERGY MODULE USER'S GUIDE

Chapter 1. Introduction

This chapter introduces the RN4020 module and includes the following topic:

- [Bluetooth Low Energy Fundamentals](#)

The RN4020 Bluetooth[®] Low Energy Module is a single mode Bluetooth Smart module that complies with Bluetooth Core Specification v4.1.

Through its high-speed UART interface, this module can be configured to act as either a central or peripheral role when establishing a connection. This module supports 13 public profiles and 17 public services, which are adopted by the Bluetooth Special Interest Group (SIG).

For all supported profiles and services, the RN4020 module can be configured to act as server and client roles at the same time. Furthermore, the RN4020 module supports the private Microchip Low-energy Data Profile (MLDP), which provides an asynchronous serial data connection between two RN4020 devices.

Finally, the Microchip RN4020 module also supports a user-defined private profile/service, which can precisely fit a user's particular application. All configurations will be saved in on-board non-volatile memory (NVM), so users need to set up the module only once.

The Microchip RN4020 module is easy to use and provides users with a fast-to-market, flexible, and powerful solution for BTLE technology.

1.1 BLUETOOTH LOW ENERGY FUNDAMENTALS

When two BTLE devices need to be connected, one is in a central role and the other in a peripheral role. The peripheral advertises its connection status, while the central device starts the connection process. Once connected, either end of the connection can initiate the bond. Once bonded, all security-related keys will be saved and the security process will be waived when reconnecting. The bonded peripheral device can only perform direct advertise; therefore, it is no longer able to connect to devices other than its bonded peer.

Similar to Bluetooth Classic, BTLE uses the concept of profiles to ensure interoperability between different devices. However, unlike Bluetooth Classic, BTLE profiles are a collection of services. All BTLE services are built on top of the Generic Attribute Profile (GATT), where GATT defines the accessibility of attributes, which are called characteristics. Therefore, the main functionality of BTLE profiles is built around these characteristics. Devices that maintain the value of characteristics in a service are the “server” of the service. Conversely, devices that acquire data from their peer are considered the “client”.

Each service and its characteristics are identified by their Universally Unique Identifier (UUID). The UUID can either be short form (16-bit) or long form (128-bit). All Bluetooth SIG adopted services and characteristics have a short UUID, whereas a user-defined private UUID must be in long form. For information on the Bluetooth SIG adopted services and characteristics, visit the Bluetooth Developer Portal at: <https://developer.bluetooth.org/gatt/profiles/Pages/ProfilesHome.aspx>.

The accessibility of each characteristic is defined by the 8-bit characteristic property in bitmap format, as shown in [Table 1-1](#).

RN4020 Bluetooth Low Energy Module User's Guide

TABLE 1-1: CHARACTERISTIC PROPERTIES

Property	Bitmap	Description
Extended Property ⁽¹⁾	0`b10000000	Additional property available.
Authenticated Write ⁽¹⁾	0`b01000000	Write characteristic with authentication from client to server.
Indicate	0`b00100000	Indicate value of characteristic with acknowledgment from server to client.
Notify	0`b00010000	Notify value of characteristic without acknowledgment from server to client.
Write	0`b00001000	Write value of characteristic with acknowledgment from client to server.
Write Without Response	0`b00000100	Write value of characteristic without acknowledgment from client to server.
Read	0`b00000010	Read value of characteristic. Value is sent from server to client.
Broadcast	0`b00000001	Broadcast value of characteristic.

Note 1: The RN4020 does not currently support this property.

Chapter 2. RN4020 OEM Module Interface

This chapter describes the interface for the RN4020 module.

The RN4020 module is a fully agent certified Bluetooth Low Energy single mode OEM module. The module is controlled by the user through input/output lines (i.e., physical device pins) and a UART interface.

The following topics are included:

- [RN4020 Control Lines](#)
- [RN4020 UART Control Interface](#)
- [Device Firmware Upgrade](#)

2.1 RN4020 CONTROL LINES

The RN4020 module uses the WAKE_SW (pin 7), CMD/MLDP (pin 8), WAKE_HW (pin 15) pins to place the module into different states, and three output pins to indicate its current status.

WAKE_SW is used to control the operating state of the RN4020. When WAKE_SW is set high, the module wakes up and is set into Active mode. Upon waking up, "CMD" will be output to the UART and indicate that the module is in Command mode and ready to take commands from UART. Conversely, when WAKE_SW is set low, the module exits Command mode by outputting "END" to the UART, and then operates in Deep Sleep mode. The UART interface will not be responsive in Deep Sleep mode unless the UART baud rate is 2400 bps. When the module is in Deep Sleep mode, MLDP_EV (pin 11) will be output low.

CMD/MLDP (pin 8) is used to control the RN4020 module when an MLDP serial data service (see [Section 2.2.5 "Microchip MLDP Commands"](#)) is used. Once MLDP mode is entered by setting CMD/MLDP high, all data from the UART is sent to the peer device as a data stream. To exit MLDP mode, CMD/MLDP must be set low so that the RN4020 module is returned to Command mode by outputting "CMD" to the UART.

Setting WAKE_HW (pin 15) high wakes the RN4020 module from Dormant mode. After powering up, if WAKE_HW flips up and down three cycles (putting the WAKE_HW pin into high, and then low, and then high again is considered one flip cycle) in the first five seconds, the RN4020 module performs a factory Reset. If WAKE_SW is high when a factory Reset is performed, the factory Reset is complete; otherwise, it is a partial factory Reset that retains the device name, private service, and scripts.

When the RN4020 module is connected to a peer device, CONNECTION LED (pin 10) will output high; otherwise, CONNECTION LED outputs low.

When in MLDP mode, if the RN4020 module must output a status to the UART or is requesting a response from the host MCU, MLDP_EV will be set high. Once the RN4020 module exits MLDP mode and returns to Command mode, status and/or requests will be output to the UART. Once stored data is output to the UART, MLDP_EV will be set low. The maximum buffer size of status and requests is 256 bytes. When the RN4020 module is in Active mode, WS (pin 12) will be output high; otherwise, it outputs low.

RN4020 Bluetooth Low Energy Module User's Guide

Figure 2-1 and Table 2-1 provide the pin diagram and their descriptions for the RN4020 module. For additional information, refer to “RN4020 Bluetooth Low Energy Module Data Sheet” (DS50002279).

FIGURE 2-1: RN4020 MODULE PIN DIAGRAM

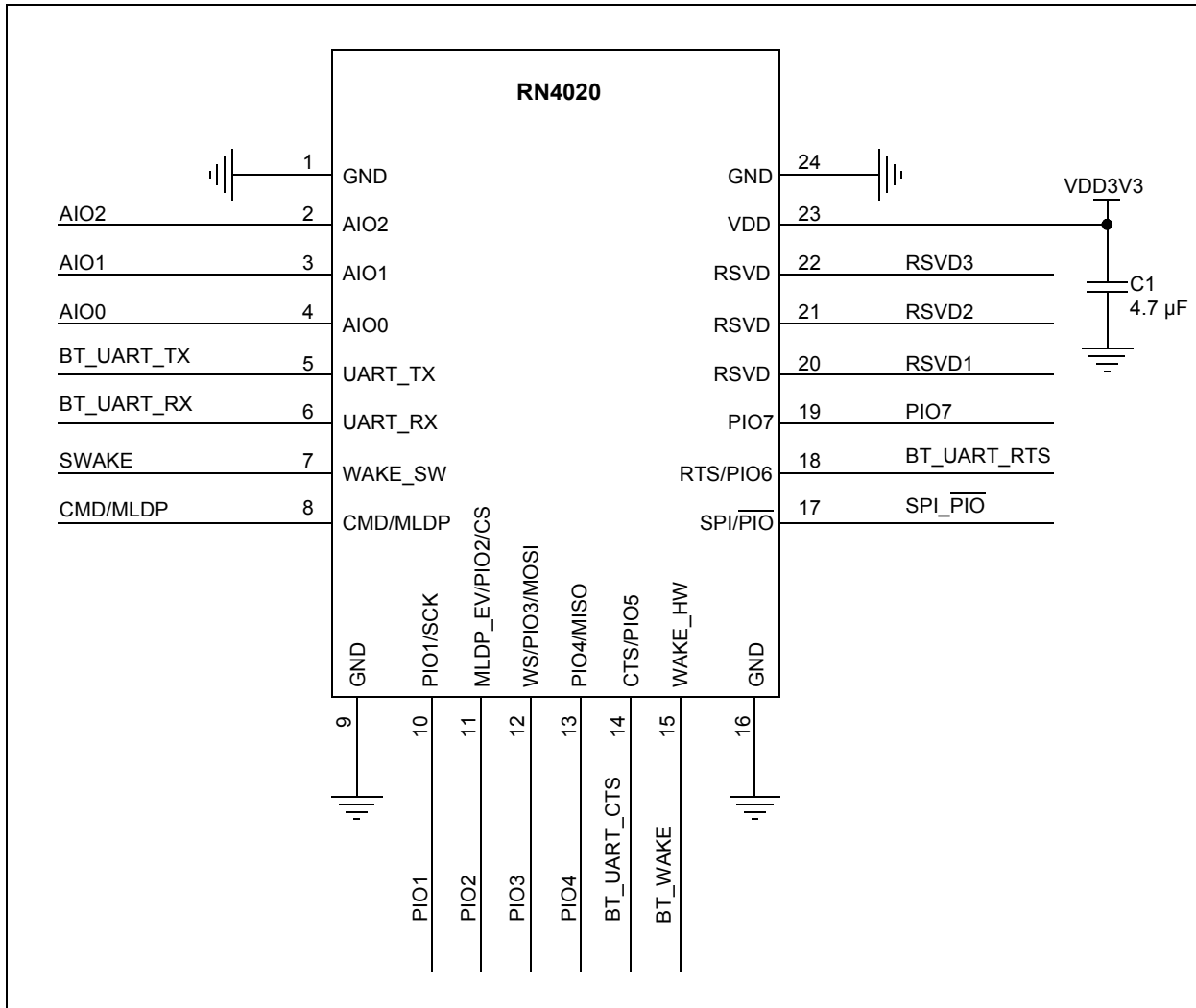

RN4020 OEM Module Interface

TABLE 2-1: RN4020 MODULE PIN DESCRIPTION

Pin	Symbol	Description	Function
1	GND	Ground.	Ground
2	AIO2	Bidirectional with programmable analog I/O.	1.65V input, 1.35V out, and 30 mA max out
3	AIO1	Bidirectional with programmable analog I/O.	1.65V input, 1.35V out, and 30 mA max out
4	AIO0	Bidirectional with programmable analog I/O.	1.65V input, 1.35V out, and 30 mA max out
5	UART_TX	UART Transmit (TX).	Output from RN4020
6	UART_RX	UART Receive (RX).	Input to RN4020
7	WAKE_SW	Deep Sleep Wake; active-high to wake module from Deep Sleep.	Input; weak pull-down
8	CMD/MLDP FACTORY RESET	<p>Command or MLDP mode – In Command mode, UART traffic is sent to the command interpreter. In MLDP mode, UART traffic is routed to the MLDP Bluetooth LED connection, if active.</p> <p>At boot time, if WAKE_HW pin is flipped three times within the first five seconds, a factory Reset is performed. If WAKE_SW is low (default) a partial factory Reset is performed, which is the same as if a “SF,1” command were executed.</p> <p>If WAKE_SW (pin7) is high and pin8 is high at boot time, a <i>full</i> factory Reset is performed, which is similar to executing a “SF,2” command.</p> <div style="border: 1px solid black; padding: 5px; text-align: center;"> <p>CAUTION</p> <p>A full factory reset erases scripts and sets the device name to the serialized name. See the SF,<1,2> command for details.</p> </div>	Input; active-high to enter Command
9	GND	Ground.	Ground
10	CONNECTION LED PIO [1] SCK	Default state is output: Active-high indicates the module is connected to a remote device. Active-high indicates a disconnected state. Configurable as PIO[1] via software command. SCK for diagnostics and factory calibration if pin 17 is asserted.	<ul style="list-style-type: none"> • Green LED • PIO[1] • SCK
11	MLDP_EV PIO [2] CS	Default function is output used for MLDP data event indicator (red LED). Active-high indicates MLDP data received or UART console data pending. Low level indicates no events. Event only triggered in CMD mode, when CMD/MLDP (pin 8) is high. Configurable as PIO[2] via “ O” and “ I” commands. CS for diagnostics and factory calibration if pin 17 is asserted.	<ul style="list-style-type: none"> • MLDP Data Event (Red LED) • PIO[2] • CS
12	WS PIO [3] MOSI	Default function is an output used for an Activity indicator (blue LED). High level indicates the module is awake and active. Low level indicates the module is in a Sleep state. Accessible as PIO[3] via “ O” and “ I” commands. MOSI for diagnostics and factory calibration if pin 17 is asserted.	<ul style="list-style-type: none"> • WS (Blue LED) • PIO[3] • MOSI

RN4020 Bluetooth Low Energy Module User's Guide

TABLE 2-1: RN4020 MODULE PIN DESCRIPTION (CONTINUED)

Pin	Symbol	Description	Function
13	PIO [4] MISO	Trigger pin to generate event @PIOH and @PIOL. MISO for diagnostics and factory calibration if pin 17 asserted.	<ul style="list-style-type: none">• PIO[4]• MISO
14	CTS PIO [5]	Reserved for CTS if hardware flow control is on the UART.	<ul style="list-style-type: none">• CTS (input)• PIO[5]
15	WAKE_HW	Hardware wake from Hibernate or Dormant state.	Active-high; internal pull down
16	GND	Ground.	Ground
17	SPI/ $\overline{\text{PIO}}$	SPI/PIO for pins 10-13, active-high.	Input with internal pull down; selects SPI on 10-13
18	PIO [6]	Reserved for RTS if hardware flow control on UART. Configurable as PIO[6] if hardware flow control is disabled.	<ul style="list-style-type: none">• RTS (output)• PIO[6]
19	PIO [7]	Spare PIO. Refer to Section 2.2.2 "Action Commands" for the "I" and "J" commands.	Spare PIO configurable as input or output
20	RSVD	Do not connect. Factory diagnostics.	No Connect
21	RSVD	Do not connect. Factory diagnostics.	No Connect
22	RSVD	Do not connect. Factory diagnostics.	No Connect
23	VDD	Supply voltage.	1.8 to 3.6V
24	GND	Ground.	Ground

2.2 RN4020 UART CONTROL INTERFACE

The UART is the main control interface for the RN4020 module. The default UART port configuration is shown in [Table 2-2](#).

TABLE 2-2: RN4020 UART CONFIGURATION

Parameter	Value
Baud Rate	115200
Data Bits	8
Parity	None
Stop Bits	1
Flow Control	None

The UART baud rate can be adjusted from 2400 to 932 Kbps with the “SB” command. When the UART baud rate is set to 2400, there is no need to wake the module via WAKE_SW (pin 7) before communicating with the module.

All control takes place through ASCII commands and their parameters. All commands and parameters are separated by commas. No spaces are allowed between commands and parameters. All commands are completed by either a line feed or a return.

All commands are divided into the following types:

- [Set/Get Commands](#)
- [Action Commands](#)
- [Characteristic Access Commands](#)
- [Private Service Configuration Commands](#)
- [Microchip MLDP Commands](#)
- [RN4020 Scripting Commands](#)
- [Remote Command](#)
- [DFU Commands](#)

[Table 2-3](#) lists and provides brief descriptions of all commands by type.

TABLE 2-3: COMMAND DESCRIPTIONS

Type	Command Name	Description
Set/Get	S-	Serialized name
	SB	Set UART baud rate
	SDF	Set firmware revision
	SDH	Set hardware revision
	SDM	Set model name
	SDN	Set manufacturer name
	SDR	Set software revision
	SDS	Set serial number
	SF	Factory default
	SM	Set Timers in μ s
	SN	Set name
	SR	Set features
	SS	Set server services
	ST	Set connection parameters

RN4020 Bluetooth Low Energy Module User's Guide

TABLE 2-3: COMMAND DESCRIPTIONS (CONTINUED)

Type	Command Name	Description
Action	+	Echo
	@O	Output analog signal
	@I	Input analog signal
	O	Set PIO's output
	I	Get PIO's input
	A	Advertise
	B	Bond
	D	Dump configuration
	E	Establish connection
	F	Start scan
	H	Help
	J	Observer role
	K	Disconnect
	M	Get RSSI from peer
	N	Enter broadcast information
	O	Enter dormant state
	R	Reboot
	T	Change parameter for current connection
	U	Unbond
	V	Firmware version
X	Stop scan	
Y	Stop advertisement	
Z	Stop connecting	
Services	LC	List client services
	LS	List server services
	CHR	Read value from client handle
	CHW	Write value of client handle
	CURC	Read configuration of client UUID
	CURV	Read value of client UUID
	CUWC	Client UUID notify/indicate start
	CUWV	Write value to client UUID
	SHR	Read value of server handle
	SHW	Write value to server handle
	SUR	Read value of server UUID
	SUW	Write value to server UUID
Private Services	PC	Set private characteristic UUID
	PS	Set private service UUID
	PZ	Clear private service
MLDP	SE	Set MLDP security mode
	I	Enter MLDP mode
Scripting	LW	Show script
	WC	Clear script
	WP	Pause script
	WR	Run script
	WW	Write script

TABLE 2-3: COMMAND DESCRIPTIONS (CONTINUED)

Type	Command Name	Description
Remote	!	Enter Remote Command mode
DFU	~	Device Firmware Update

2.2.1 Set/Get Commands

This group of commands is used to configure specific functions of the RN4020 module. The Set commands start with the letter S and are followed by one or two letters as the command identifier. The Set command parameters are mandatory and are separated from the command by a comma. The format of the Set commands is provided in [Example 2-1](#).

EXAMPLE 2-1: SET COMMAND FORMAT

S	Command Identifier	,	Input Parameter
---	--------------------	---	-----------------

A reboot is required for most Set commands to ensure the new settings will take effect. Configurations from the Set commands are stored in the non-volatile memory (NVM) of the RN4020 module and restored after a power cycle or reset. All Set commands have a corresponding Get command to output the configurations to the UART. Get commands have the same command identifier as Set commands, but have no parameters.

S-, <string>

Description

This command sets the serialized Bluetooth-friendly name of the device, where <string> is up to 15 alphanumeric characters. This command automatically appends the last 2 bytes of the Bluetooth MAC address to the name, which is useful for generating a custom name with unique numbering.

Default:

Not applicable.

Example

```
S-,MyDevice // Set device name to "MyDevice-ABCD"
```

RN4020 Bluetooth Low Energy Module User's Guide

SB, <0-7>

Description

This command sets the baud rate of the UART communication. The input parameter is a single digit number in the range of 0 to 7, representing a baud rate from 2400 to 921K, as shown in [Table 2-4](#). When the baud rate is set to 2400, there is no need to wake the RN4020 module by pulling WAKE_SW high for UART communication.

TABLE 2-4: UART BAUD RATE SETTINGS

Setting	Baud Rate	Comments
0	2400	When the UART is set to 2400 Kbps, the RN4020 module can remain in Deep Sleep. In other words, when set to 2400 Kbps, the UART is always accessible; therefore, the WAKE_SW line does <i>not</i> need to be pulled high to wake the RN4020 module for UART access.
1	9600	—
2	19200	—
3	38400	—
4	115200	—
5	230400	—
6	460800	—
7	921600	—

SDF, <text>

Description

This command sets the value of the firmware revision characteristic in the Device Information Service.

The Device Information Service is used to identify the device. Since all of its characteristics rarely change, the values of the characteristics in the Device Information Service can be set and saved into NVM. All characteristic values in the Device Information Service have a maximum size of 20 bytes.

Default:

Determined by firmware version.

Example

SDF, 0.9

SDH, <text>

Description

This command sets the value of the hardware revision characteristics in the Device Information Service.

Default

Determined by hardware version.

Example

SDH, 2.1

SDM, <text>

Description

This command sets the value of the model characteristics in the Device Information Service.

Default

RN4020

Example

SDM, RN4020

SDN, <text>

Description

This command sets the value of the manufacturer name characteristics in the Device Information Service.

Default

Microchip

Example

SDN, Microchip

SDR, <text>

Description

This command sets the value of the software revision characteristics in the Device Information Service.

Default

Determined by software version.

Example

SDR, 1.0

SDS, <text>

This command sets the value of the serial number characteristics in the Device Information Service.

Default

The MAC address of the device.

Example

SDS, 12345678

SF, <1, 2>

This command resets the configurations to the factory default at the next reboot. The parameters of this command are '1' and '2'.

When the input parameter is '1', a majority of the settings will be restored to the factory default, but some settings, such as device name, device info, script and private services, stay the same. When the input parameter is '2', all parameters are restored to factory default.

Default

Not applicable.

Example

SF, 1

SM, <1-3>, <hex32>

This command starts one of the application timers. The first parameter is the identifier of the timer to start, and the second parameter is the timer expiration time in microseconds if the value is in the range between 0x00000001 and 0x7FFFFFFF. The second parameter outside the this range will stop the timer.

Default

Not applicable.

Example

```
SM,1,000f4240      // Start Timer1 to expire in 1 second
SM,1,FFFFFFFF      // Stop Timer1 immediately
```

SN, <string>

Description

This command sets the device name, where <string> is up to 20 alphanumeric characters.

Default

Not applicable.

Example

```
SN,MyDevice       // Set the device name to "MyDevice"
```

RN4020 Bluetooth Low Energy Module User's Guide

SR, <hex32>

Description

This command sets the supported features of current RN4020 module. The input parameter is a 32-bit bitmap that indicates features to be supported. After changing the features, a reboot is necessary to make the changes effective. The bitmap of features is shown in [Table 2-5](#).

TABLE 2-5: BITMAP FEATURES

Feature	Bitmap	Description
Central	0x80000000	If set, the device that starts the connection is central. If cleared, the device that starts advertisement is peripheral.
Real-time Read	0x40000000	If set, the device request values from the host MCU through the UART and the host MCU must respond in a timely manner. If cleared, the device reads from the internal RAM of the RN4020 for the characteristic values that were previously set.
Auto Advertise	0x20000000	This setting only applies to a peripheral device. If set, the device starts advertisement after a power cycle, reboot, or disconnection. If cleared, the device starts advertisement after receiving command "A" from the UART in Command mode.
Support MLDP	0x10000000	If set, the device supports the private service MLDP that provides asynchronous serial data over Bluetooth LE. If cleared, MLDP is disabled. See Section 2.2.5 "Microchip MLDP Commands" for more information.
Auto MLDP Disable	0x08000000	This setting is only effective when MLDP is enabled. If set, the device enters MLDP mode after receiving command "I" from the UART in Command mode, or when CMD/MLDP (pin 8) is set high. If cleared, the device enters MLDP mode not only by command "I" or the CMD/MLDP pin, but also by receiving an MLDP data stream from the peer device.
No Direct Advertisement	0x04000000	This setting is only effective for peripheral devices. If set, the peripheral will not issue a direct advertisement even if it is bonded; therefore, it is discoverable whenever it is advertising. This setting is useful when working with iOS or Android devices.
UART Flow Control	0x02000000	This setting is used to control RTS/CTS hardware flow control on the RN4020 module UART port. If set, flow control is enabled and the host needs to support the UART hardware flow control feature. Flow control is required when MLDP is enabled.
Run Script After Power On	0x01000000	This setting is used to control script execution. If set, after powering on, script execution will be automatically started by generating a @PW_ON event.
Reserved	0x00800000	—

RN4020 OEM Module Interface

TABLE 2-5: BITMAP FEATURES (CONTINUED)

Feature	Bitmap	Description
Enable Authentication	0x00400000	This setting enables authentication during connection, preventing a Man-In-The-Middle (MITM) attack. When authentication is enabled, I/O capability is set to be keyboard and/or display. For details, refer to <i>Table 2.5: "Mapping of IO Capabilities to STK Generation Method"</i> in <i>Vol 3, Part H, Section 2.3.5.1 "Selecting STK Generation Method"</i> in "Bluetooth Core Specification v4.1".
Enable Remote Command	0x00200000	This setting is only effective if the MLDP feature is enabled. This setting enables the local device to receive remote commands from a remote device and to send command output to a remote device through the MLDP data stream.
Do not Save Bonding	0x00100000	Once set, the bonding information will not be saved in NVM and the bonding is only valid for the current connection.
I/O Capabilities	0x000E0000	I/O capability of the module. Only useful if the Enable Authentication bit is set. <ul style="list-style-type: none"> • `b000 = Display Only • `b001 = Display Yes/No • `b010 = Keyboard Only • `b011 = No Input, no output • `b100 = Keyboard Display
Block Set Commands in Remote Command Mode	0x00010000	If set, all "Set" commands are no longer effective in Remote Command mode.
Enable OTA	0x00008000	If set, DFU over the air is effective. Otherwise, support of DFU OTA is disabled.
iOS Mode	0x00004000	If set, connection parameters will be checked against Apple® Bluetooth Accessory Design Guidelines. See the ST,<interval>,<latency>,<timeout> command for details.
Server Only	0x00002000	If set, the RN4020 module will not act as a client. No service discovery will be performed after connection to save connection time and power.
Enable UART in Script	0x00001000	If set, allow normal UART output when running a script.
Auto-enter MLDP Mode	0x00000800	If set, and the Support MLDP bit is also set, once connected, the RN4020 module automatically enters MLDP mode.
MLDP without Status	0x00000400	If set, no additional status string, such as "CMD", "Connected", and "Connection End", is in the UART output.

Default

00000000

Example

```
SR,20000000 // Set device as peripheral, and
// automatically start advertisement
```

RN4020 Bluetooth Low Energy Module User's Guide

`SS, <hex32>`

Description

This command sets the services supported by the device in a server role. The input parameter is a 32-bit bitmap that indicates the services supported as a server. Supporting the service-as-server role means that the host MCU needs to supply the values of all characteristics in the supported services and provides client access to those values upon request. The values for the service characteristics are written to the server database using 'SSW' commands. Once the service bitmap is modified, the device must reboot to make the new services effective. The 32-bit bitmap is provided in [Table 2-6](#).

TABLE 2-6: BITMAP SERVICES

Service	Bitmap	Used in Profiles
Device Information	0x80000000	Blood Pressure, Cycling Speed Cadence, Glucose, Health Thermometer, Heart Rate, Running Speed Cadence
Battery	0x40000000	
Heart Rate	0x20000000	Heart Rate
Health Thermometer	0x10000000	Health Thermometer
Glucose	0x08000000	Glucose
Blood Pressure	0x04000000	Blood Pressure
Running Speed Cadence	0x02000000	Running Speed Cadence
Cycling Speed Cadence	0x01000000	Cycling Speed Cadence
Current Time	0x00800000	Time
Next DST Change	0x00400000	Time
Reference Time Update	0x00200000	Time
Link Loss	0x00100000	Proximity
Immediate Alert	0x00080000	Find Me, Proximity
TX Power	0x00040000	Proximity
Alert Notification	0x00020000	Alert Notification
Phone Alert Status	0x00010000	Phone Alert Status
Scan Parameters	0x00004000	Scan Parameters
User Defined Private Service	0x00000001	User Defined Private Profile

Default

80000000

Example

```
SS,060000          // Support blood pressure and running speed
                   // cadence as server role
```

ST,<interval>,<latency>,<timeout>

Description

This command sets the initial connection parameters for future connections. The three input parameters are all 16-bit values in hexadecimal format. To modify the current connection parameters, refer to the action command “T”.

For a central device, the connection parameters will be used to establish connections with peripherals. For a peripheral device, the connection parameters are used to request the connection update once a new connection is established. Acceptance of the connection update from a peripheral device depends on the central device.

The corresponding Get command “GT” returns the desirable connection parameters set by the “ST” command when a connection is not established. Once a connection is established, the actual connection parameters will be displayed in response to the command “GT”.

Note: Every Set command has a corresponding Get command, which is used to obtain the setting. See [Section 2.2.1 “Set/Get Commands”](#) for more information.

Connection interval, latency and timeout are often associated with how frequently a peripheral device needs to communicate with central and is therefore closely related to power consumption. The three parameters’ ranges and relationships are listed in [Table 2-7](#).

TABLE 2-7: CONNECTION PARAMETERS

Parameter	Range	Default Value	Description
Interval	0x0006-0x0C80	0006	The time interval of communication between two connected devices. (unit: 1.25 ms)
Latency	0x0000-0x01F3 Must less than: (Timeout * 10 / Interval * 1.25 - 1)	0000	The number of consecutive connection events that the peripheral does not need to communicate with central.
Timeout	0x000A-0x0C80	0064	The maximum time between raw communications before the link is considered lost. (unit: 10 ms)

Apple iOS devices have a special requirement of these parameters. As a result, if connection with an iOS device is expected, the iOS Mode bit in the “SR” command (see the [SR,<hex32>](#) command) will be enabled and the following rules must be applied:

- Interval ≥ 16
- Latency ≤ 4
- Timeout ≤ 600
- (Interval + 16) * (Latency + 1) < Timeout * 8 / 3

Default

0006,0000,0064

Example

```
ST,0064,0002,0064 // Set the interval to 125 ms,
                  // latency to 2, and time-out to 1 second
```

2.2.2 Action Commands

The group of action commands are mainly used to initiate functionality, as well as display critical information.

+

This command toggles the local echo on and off. If the “+” command is sent in Command mode, all typed characters are echoed to the output. Entering the “+” command again will turn local echo off.

Default

Off

Example

```
+          // Turn on local echo
```

```
@O,<0-2>,<hex16>
```

```
@I,<0-2>
```

Description

These commands set the analog port output (O) and get the input (I) voltage. The first parameter can be 0, 1, or 2, which specifies the analog port number. The second parameter is only for analog output, which sets the output voltage in mV. The range of output/input voltage is 0V to 1.3V (valid range is 0x0000 to 0x0514).

When outputting the analog signal, the RN4020 module cannot operate in Deep Sleep mode. Instead, the firmware will automatically adjust the operation mode to Shallow Sleep. Once the analog output is turned off by issuing the command @O,<0-2>,0000, the firmware will again automatically adjust the operation mode back to Deep Sleep mode, when available.

Default

Not applicable.

Example

```
@O,1,03E8    // Set AI01 output voltage to be 1000 mV
```

```
| O, <hex8>, <hex8>  
| I, <hex8>
```

Description

The “|O” and “|I” commands set the output (O) and get the input (I) on the digital I/O pins (PIO1, PIO3, and PIO7). The first input parameter is a bitmap to indicate which PIO is affected by this command and the second parameter indicates the digital value to set. [Table 2-8](#) shows the bitmap of the pins. Notice that PIO1 through PIO3 are used as output to indicate status by default. For example, the RN4020 PICtail™ Daughter Board uses these status PIOs to drive indicator LEDs (see [Appendix A. “PICtail™ Daughter Board Schematics”](#)). Once these pins are read or written by setting the first three bits in the first parameter, the status is no longer output and the user has full control over the pins.

TABLE 2-8: BITMAP OF “|O” AND “|I” COMMANDS

Bitmap	PIO
0`b00000001	PIO1
0`b00000010	PIO2
0`b00000100	PIO3
0`b00001000	PIO7

Default

Not applicable.

Example

```
|O,07,05          // Set PIO1 and PIO3 output to be high and PIO2  
                  // output to be low  
  
|I,06            // Read states of PIO2 and PIO3. The result is a one  
                // byte bitmap. If the result is 04, PIO2 is low  
                // and PIO3 is high.
```

CAUTION

Accessing PIO1-PIO3 will disable the default behavior of serving as status indicators (blue, green, red).

A, <hex16>, <hex16>

This command is only available to a device that operates as a peripheral or in a broadcaster role.

The “A” command is used to start advertisement. When the device acts in a broadcaster role, which is enabled by the “N” command, the advertisement is an undirected, unconnectable, manufacturer-specific broadcast message. The payload of the message is set by the “N” command.

When the device acts in a peripheral role and it is not bonded, the advertisement is undirected connectable, which means it is discoverable by all BTLE central devices. When the device is bonded, the advertisement is directed if the `no_direct_adv` bit is cleared using the “SR” command; otherwise, the advertisement is undirected if the `no_direct_adv` bit is set. When direct advertisement is used, it is directed to the bonded device so that other BTLE devices are not heard.

When the “A” command is issued without a parameter, by default, the advertisement interval is 100 ms and advertising is indefinite. The “A” command can be followed by two 16-bit hex parameters, which indicates an advertisement interval in milliseconds and total advertisement time in milliseconds. The second parameter must be larger than the first parameter.

Default

100 ms

Example

```
A,0050,07D0      // Start advertisement with interval of
                  // 80 milliseconds for 2 seconds
```

B, <0, 1>

This command is used to secure the connection and bond two connected devices. The “B” command is only effective if two devices are already connected. Bonding can be issued from either a central or a peripheral device.

If no input parameter is provided or the input parameter is ‘1’, the connection will be secured and the peer device remembered. In this situation, the two devices are considered bonded. If the input parameter is ‘0’, the connection is secured; however, the peer device is not saved into NVM. In this situation, the connection is not bonded.

Once bonded, security information is saved to both ends of the connection if the “do_not_save_bonding” setting is cleared using the “SR” command. Therefore, reconnection between bonded devices does not require authentication, allowing reconnection to be done in a short amount of time. For bonded peripheral devices, advertisement can only be directed. As a result, bonded peripheral devices are not available for inquiry or connection.

After a bonded connection is lost due to any reason, reconnection does not provide a secured link automatically. To secure the connection, another “B” command will be issued. However, this command is only for securing links rather than saving connection information.

Default

‘0’ (Not bonded)

Example

```
B // bond with connected peer device
```

D

This command displays critical information about the current device over the UART. The following information will be output after issuing a “D” command:

- Device MAC Address
- Device Name
- Device Connection Role (Central or Peripheral)
- Connected Device: Show the MAC address and address type (Public or Random) if connected, or “no” if no active connection
- Bonded Device: Show the MAC address and address type (Public or Random) if connected, or “no” if no bonding device
- Server Services: Bitmap of services that are supported in the server role

Default

The “D” command has no parameters.

Example

```
D // Dump information
```

E, <0,1>, <mac address>

The “E” command starts the process to establish a connection with a peer peripheral device.

Note: This command is only available to devices in a central role.

If the central device is already bonded with a peripheral, issuing the “E” command without parameters will automatically start the process of connecting with the bonded peripheral. Usually, the bonded central device needs to first issue the “E” command, and then the bonded peripheral starts the directed advertisement.

If the central device is not bonded with the peripheral, two input parameters are required to establish connection with a peripheral device. The first parameter is the MAC address type, and second parameter is the MAC address of the peripheral device. The MAC address type is either ‘0’ for public address or ‘1’ for a random address. The address type will be available in the result of an inquiry using the “F” command. The second parameter is a 6-byte MAC address, which is also available as a result of using the “F” command.

Default

Bonded MAC address

Example

```
E,0,00035B0358E6 // Connect to peripheral with
                  // public address 00035B0358E6
```

F, <hex16>, <hex16>

This command is only available to a device in a central or observer role. For a central device, it is used to query the peripheral devices before establishing a connection. For the observer role, it is used to receive broadcast messages.

If no parameter is provided, the “F” command starts the active scan process with a default scan interval of 375 milliseconds and a scan window of 250 milliseconds. The user has the option to specify the scan interval and scan window as the first and second parameter, respectively, as a 16-bit hex value in milliseconds.

Default

375 ms for scan interval, 250 ms for scan window.

Example

```
F,012C,00C8 // Start inquiry with 300 ms scan interval
             // and 200 ms scan window
```

H

This command sends a help page to the UART. The help page is grouped into “Set Commands”, “Action Commands”, “Service Commands”, “Private Service Commands” and “MLDP Commands”. According to the feature settings from “Set Commands”, the help page displays only commands that apply to the current settings.

Default

The “H” command has no parameters.

Example

```
H      // Display the help page
```

J, <0, 1>

This command places the device into or out of an observer role.

If the input parameter is ‘1’, the RN4020 module enters Observer mode. After issuing the “F” command, the RN4020 module is able to receive undirected, unconnectable advertisements from broadcasters. If the input parameter is ‘0’, the RN4020 module exits Observer mode.

Default

Not applicable.

Example

```
J,1    // Enter observer mode. To receive broadcast,  
        // the “F” command must be issued.
```

K

This command is used to disconnect the active BTLE link. The “K” command can be used in a central or peripheral role. An error is returned if there is no connection.

Default

The “K” command does not have any parameters.

Example

```
K      // Kill the active BTLE connection
```

M

This command is used to obtain the signal strength of the last communication with the peer device. The signal strength can be used to estimate the distance between the device and its peer.

The return value of the “M” command is the Received Signal Strength Indication (RSSI) in dBm. The accuracy of the result is within 6 dBm.

Default

The “M” command does not have any parameters.

Example

```
M          // Check the signal strength of the last
           // communication with the peer device
```

N, <hex>

This command is used to place the RN4020 module into a broadcaster role and to set the advertisement content. The input parameter is in hexadecimal format, with a limit of up to 25 bytes. After setting the advertisement content, use the “A” command to start advertisement.

Default

The “N” command does not have any parameters.

Example

```
N,11223344 // Place RN4020 module into a broadcaster role and set
           // advertisement content to be 0x11, 0x22, 0x33, and 0x44.
```

O

This command places the module into a Dormant mode that consumes very little power, and can be issued by either a central or peripheral device.

When the RN4020 module is in Dormant mode, power consumption is less than 700 nA. For comparison, power consumption is less than 5 μ A in Deep Sleep mode. Once the RN4020 module enters Dormant mode, the WS pin (pin 10, PIO1/BLUE LED) will assert low and all connection will be lost, as well as any data in RAM. To exit Dormant mode and enter Deep Sleep, pull the WAKE_HW pin (pin 15) high. Once the module has exited from Dormant mode, it behaves the same as after a reboot. To exit Deep Sleep and enter Active mode, pull WAKE_SW high.

Default

The “O” command does not have any parameters.

Example

```
O          // Enter low-power dormant mode
```

R, 1

This command forces a complete device reboot (similar to a power cycle). It has one mandatory parameter of '1'. After rebooting the RN4020 module, all prior change settings take effect.

Default

Not applicable.

Example

```
R,1 // Reboot the RN4020 module
```

T, <interval>, <latency>, <timeout>

This command is used to change the connection parameters, interval, latency, and time-out for the current connection. The parameters of the “T” command are lost after a power cycle. All parameters are 16-bit values in hexadecimal format. The “T” command is only effective if an active connection exists when the command is issued.

For the definitions, ranges and relationships of connection interval, latency, and timeout, please refer to the “ST” command and [Table 2-7](#) for details.

When a “T” command with valid parameters is issued by a peripheral device, a minimum time-out interval is required between the two connection parameter update requests. Also, whether to accept the connection parameter update request is up to the central device. When the RN4020 module acts as a central device, it accepts all valid connection parameter update requests.

Default

Interval: 6

Latency: 0

Time-out: 100

Example

```
T,0190,0001,03E8 // Request Connection Parameter
                  // to be interval 400 ms, latency 1,
                  // and timeout 1000 ms
```

U

This command removes the existing bonding. The “U” command not only removes the bonding, but it also changes the advertisement method. If a peripheral is advertising when a “U” command is issued, the RN4020 module will remove the bonding, stop the directed advertisement, and then start undirected advertisement.

Default

The “U” command does not have any parameters and can be issued by either the central or peripheral device.

Example

```
U // Remove existing bond
```

V

This command displays the firmware version.

Default

Not applicable.

Example

```
V // Display the firmware version
```

X

This command is only available to a central or observer device. For a central device, it stops the inquiry process. For observers, it stops receiving broadcast messages.

Default

The “X” command does not have any parameters.

Example

```
X // Stop inquiry
```

Y

This command is only available to a peripheral or broadcaster device. It stops advertisement that was started by an “A” command.

Default

The “Y” command does not have any parameters.

Example

```
Y // Stop advertisement
```

Z

This command is only available to a central device. It stops the connection process that was started by an “E” command.

Default

The “Z” command does not have any parameters.

Example

```
Z // Stop the connection process
```

2.2.3 Characteristic Access Commands

The main functionality of BTLE profiles and services are providing access to the values and configurations of characteristics. The RN4020 module provides a set of commands to address this issue.

2.2.3.1 DEFINITION OF CHARACTERISTIC ACCESS COMMANDS

The RN4020 module can be configured to act as a server and client at the same time. When it performs dual roles as the server and client, two sets of services and characteristics are known to the RN4020 module. For services where the RN4020 module acts as the server, these are called “server services”, where all values and configurations of characteristics are stored locally. For services where the RN4020 module acts as the client, these are called “client services”, where all data and configurations of the characteristics are stored remotely in the peer device. To address server services, the first letter of a characteristic access command is “S”, and to address client services, the first letter of a characteristic access command is “C”.

The Bluetooth SIG adopted a group of public services specifications, which are the basis of interoperability between devices. All Bluetooth SIG public service and characteristics in the service have been assigned 16-bit short UUIDs. However, users are able to define their own private service and its associated characteristics with 128-bit long UUIDs. Conversely, even though it is rare, one public characteristic may be used in more than one service. Furthermore, because addressing a 128-bit private characteristic may not be very efficient, the RN4020 module provides a unique 16-bit reference handle to each characteristic. Therefore, a characteristic can be addressed either by its UUID or its handle. To address a characteristic by its UUID, the second letter of a characteristic access command is “U”, and to address a characteristic by its handle, the second letter of a characteristic access command is “H”.

In addition, the value or configuration of a characteristic can either be read or write. To read a characteristic, the third letter of a characteristic access command is “R”, and to write a characteristic, the third letter of a characteristic access command is “W”.

Finally, access to a characteristic may be directed to its value or its configuration. Usually, only client services need to access the configuration of a characteristic. If the address is done by handle, this problem has been solved, since the value and configuration of a characteristic have different handles. However, if addressing is done by UUID, a fourth letter “V” or “C” needs to be added to indicate whether the access request to client service is for either the value (V) or the configuration (C) of a characteristic.

Before addressing the characteristics, users may want to determine the accessible characteristics. The Characteristic Access Commands group provides two commands, “LC” and “LS”, to list the client services and server services, respectively.

LC

This command lists the available client services and their characteristics. Client services and their characteristics are only available under two conditions:

- An active connection exists
- Peer device supports services in a server role

The output of the “LC” command follows this format:

- The first line is the primary service UUID
- The second line starts with two spaces, and then follows the characteristic UUID, handle, and characteristic property
- The property for the characteristic value follows the definitions shown in [Table 1-1](#) in [Chapter 1. “Introduction”](#). The property for the characteristic value must have bit 4 and bit 5 cleared (no notification or indication), while the property for the characteristic configuration must have either bit 4 or bit 5 set

[Example 2-2](#) shows the Battery Service output. 0x180F is the UUID for the Battery Service. The second line shows that the Battery Level UUID is 0x2A19, its handle is 0x001A and the property is 0x02 (Readable, a value handle (see [Table 1-1](#))). The third line shows that the Battery Level UUID is 0x2A19, its handle is 0x001B and its property is 0x10 (Notify, a configuration handle).

When the “LC” command has no parameter, it displays all client services along with their characteristics. Optionally, the “LC” command can accept one or two parameters.

If one parameter is provided to the “LC” command, it must be the UUID of the client service. Then, only the client service with the provided UUID along with all of its characteristics will be displayed. If two parameters are provided to the “LC” command, the first parameter is the UUID of the client service, and the second parameter is the UUID of its characteristic. Only the characteristic with the provided UUID in the client service with the given UUID is displayed.

EXAMPLE 2-2: LISTING CLIENT SERVICE AND CHARACTERISTICS

```
180F
 2A19,001A,02
 2A19,001B,10
```

LS

This command lists the server services and their characteristics.

The output format of the “LS” command is similar to that of the “LC” command, as follows:

- The first line is the primary service UUID
- The second line starts with two spaces, and then follows the characteristic UUID, handle, and letter “V” or “C” to indicate the value handle or configuration handle, respectively.

Example

```
LS // Display all server services
```

CHR

The “CHR” command reads the content of the characteristic of the client service from a remote device by addressing its handle.

The parameter of the “CHR” command is the 16-bit hexadecimal value of the handle, which corresponds to a characteristic of the client service. Users can find a match between the handle and its characteristic UUID using the “LC” command.

This command is only effective if an active link with a peer exists, the handle parameter is valid, and the corresponding characteristic is readable according to its property. The value returned is retrieved from the remote peer device.

Example

```
CHR,001A          // Read the content of the characteristic with
                  // the handle 0x001A from a remote device
```

CHW

The “CHW” command writes the contents of the characteristic in the client service from a remote device by addressing its handle.

This command expects two parameters. The first parameter is the 16-bit hexadecimal value of the handle, which corresponds to a characteristic of the client service. Users can find a match between the handle and its characteristic UUID using the “LC” command. The second parameter is the content to be written to the characteristic. The format of each public characteristic is defined in the Bluetooth SIG specifications. The format of each private characteristic is defined by the user.

This command is only effective if an active link with a peer exists, the handle parameter is valid, and the corresponding characteristic is writable according to its property. The content value is written to the remote peer device. The writing method depends on the property of the characteristic.

When writing to a configuration handle of a remote device, the Bluetooth Specification defines the format to be 0x0000, 0x0001, or 0x0002. Value 0x0001 (01 00 over the air in little-endian) starts notification, value 0x0002 (02 00 over the air in little-endian) starts indication, and value 0x0000 stops both of them. To start notification or indication depends on the service specification, as well as the property of the characteristic. Please refer to [Table 1-1](#) in [Chapter 1. “Introduction”](#) and [Example 2-2](#) for details.

Example

```
CHW,001A,64      // Set the value of the characteristic
                  // with the handle value 0x001A to be
                  // 100 on the remote device

CHW,001B,0100    // Start notification on the characteristic
                  // by writing 0x0001 to its configuration
                  // handle 0x001B on the remote device
```

CURC

The “CURC” command reads the configuration of a characteristic in the client service from a remote device by addressing its UUID.

This command expects one parameter, which is the UUID of the characteristic in the client service. The UUID can be either a 16-bit short UUID for a public characteristic, or a 128-bit long UUID for a private characteristic. Only characteristics with a property of notification or indication have a configuration and, therefore, are addressable by this command.

This command is only effective if an active link with a peer exists and the UUID parameter is valid. The configuration of a characteristic, if it exists, is always readable. The value returned is retrieved from the remote peer device. The return value is 0000, 0100, or 0200, or endian format for value 0x0000, 0x0001, and 0x0002. A return value of 0000 means no indication or notification started, a return value of 0100 means a notification started, and 0200 means an indication started.

Example

```
CURC,2A19          // Read the configuration of the characteristic
                   // Battery Level with the UUID 0x2A19 from the
                   // remote device
```

CURV

The “CURV” command reads the value of a characteristic in the client service from a remote device by addressing its UUID.

This command expects one parameter, which is the UUID of the characteristic in the client service. The UUID can be either a 16-bit short UUID for a public characteristic, or a 128-bit long UUID for a private characteristic.

This command is only effective if an active link with a peer exists, the UUID parameter is valid, and the characteristic is readable according to its property. The value returned is retrieved from the remote peer device.

Example

```
CURV,2A19          // Read the value of the characteristic
                   // Battery Level with the UUID 0x2A19
                   // from the remote device
```

CUWC

The “CUWC” command writes the configuration of a characteristic in the client service to a remote device by addressing its UUID.

This command expects two parameters. The first parameter is the UUID (either a 16-bit short UUID or a 128-bit long UUID) of the characteristic. The second parameter is either ‘0’ or ‘1’. Parameter ‘1’ starts notification or indication, depending on the property of the configuration handle. Parameter ‘0’ turns off notification or indication. Only characteristics with a property of notification or indication have a configuration and, therefore, are addressable by this command.

This command is only effective if an active link with a peer exists and the UUID parameter is valid. The characteristic configuration, if it exists, is always writable.

Example

```
CUWC,2A19,1 // Start notification on the remote device
             // for the characteristic Battery Level with
             // the UUID 0x2A19
```

CUWV

The “CUWV” command writes the value of a characteristic in the client service to a remote device by addressing its UUID.

This command expects two parameters. The first parameter is the UUID (either a 16-bit short UUID or a 128-bit long UUID) of the characteristic. The second parameter is the hexadecimal value of the contents to be written. The format of the public characteristic is defined in the Bluetooth SIG specifications. The format of the private characteristic is defined by the user.

This command is only effective if an active link with a peer exists, the UUID parameter is valid, and the characteristic is writable according to its property. The content value is written to the remote peer device. The writing method depends on the property of the characteristic.

Example

```
CUWV,2A19,64 // Write 100% to the remote device for the
              // characteristic Battery Level with the
              // UUID 0x2A19
```

SHR

The “SHR” command reads the contents of the characteristic of the server service on a local device by addressing its handle.

The parameter of the “SHR” command is the 16-bit hexadecimal value of the handle, which corresponds to a characteristic of the server service. Users can find a match between the handle and its characteristic UUID using the “LS” command.

This command is effective with or without an active link. Reading the contents of a characteristic locally is always permitted regardless of characteristic property. The characteristic property is only used for remote access. The value returned is retrieved from the local device and equal to what was written the most recently.

Example

```
SHR,001A          // Read the local content of the characteristic
                  // with the handle 0x001A
```

SHW

The “SHW” command writes the contents of the characteristic in the server service to a local device by addressing its handle.

This command takes two parameters. The first parameter is the 16-bit hexadecimal value of the handle, which corresponds to a characteristic of the server service. Users can find a match between the handle and its characteristic UUID using the “LS” command. The second parameter is the content to be written to the characteristic. The format of each public characteristic is defined in the Bluetooth SIG specifications. The format of each private characteristic is defined by the user.

This command is effective only if the handle is valid in the server service. The characteristic in the server service is always writable regardless of its property. The characteristic property is only for remote access. The contents of a configuration handle, which starts or stops notification/indication, is usually set remotely. It is highly recommended to not write to the configuration handle, although that operation is not prohibited.

When the Real-Time Read feature is enabled (see the “SR” command), the RN4020 module requests the contents of a characteristic from the host MCU when receiving a read request from the remote device. The host MCU needs to use the “SHW” or “SUW” command to write the contents and, therefore, responds to the request.

When the “SHW” command is used to change the local contents of a characteristic, a notification or indication will be sent to the remote device, provided the following conditions are met:

- An active connection exists
- The remote device supports the corresponding service and characteristic in a client role
- The property of the corresponding characteristic supports notification or indication
- The notification or indication service for the corresponding characteristic has been started by the remote device

Example

```
SHW,001A,64      // Set the local value of characteristic Battery
                  // Level with value handle 0x001A to be 100%. If the
                  // notification service was previously started on
                  // Battery Level, the local device will notify the
                  // new value of 100% to the remote peer device
```

SUR

The “SUR” command reads the value of the characteristic in the server service on a local device by addressing its UUID.

The parameter of the “SUR” command is the hexadecimal value of the UUID of a characteristic. The UUID can be either a 16-bit short UUID for a public characteristic, or a 128-bit long UUID for a private characteristic.

This command can only read the value of a characteristic. Generally, the configuration of a characteristic in a server service is accessed remotely by a peer device. Therefore, the local device does not care about the setting. If the user needs to know the configuration of a local characteristic, the “SHR” command will be used to retrieve this information.

This command is effective with or without an active link. Reading the value of a characteristic locally is always permitted regardless of the characteristic property. The characteristic property is only used for remote access. The value returned is retrieved from the local device and is equal to what was written the most recently.

Example

```
SUR,2A19          // Read the local value of the characteristic with
                  // the UUID 0x2A19
```

SUW

The “SUW” command writes the contents of the characteristic in the server service to a local device by addressing its UUID.

This command takes two parameters. The first parameter is the hexadecimal value of the UUID of a characteristic. The UUID can be either a 16-bit short UUID for a public characteristic, or a 128-bit long UUID for a private characteristic. The second parameter is the content to be written to the characteristic. The format of each public characteristic is defined in the Bluetooth SIG specifications. The format of each private characteristic is defined by the user.

The “SUW” command is effective only if the UUID is valid in the server service. The characteristic in the server service is always writable regardless of its property. The characteristic property is only for remote access. The configuration of a characteristic, which starts or stops notification/indication, is usually set remotely. Therefore, the “SUW” command cannot be used to modify the configuration of a local characteristic. In the exceptional case that such a configuration has to be modified, the “SHW” command will be used.

When the Real-Time Read feature is enabled (see the “SR” command), the RN4020 module requests the contents of a characteristic from the host MCU when receiving a read request from the remote device. The host MCU needs to use the “SHW” or “SUW” command to write the content and, therefore, responds to the request.

When the “SUW” command is issued to change the local contents of characteristic, a notification or indication will be sent to the remote device, provided the following conditions are met:

- An active connection exists
- The remote device supports the corresponding service and characteristic in a client role
- The property of the corresponding characteristic supports notification or indication
- The notification or indication service for the corresponding characteristic has been started by the remote device

Example

```
SUW,2A19,64 // Set the local value of the characteristic Battery
             // Level with value handle 0x001A to be 100%. If the
             // notification service was previously started on
             // Battery Level, the local device will notify the
             // new value of 100% to the remote peer device
```

2.2.4 Private Service Configuration Commands

The Bluetooth SIG Specification defines public profiles, services, and characteristics to ensure interoperability between devices. Alternatively, it is possible to define a private service to address unique requirements not provided by a public service. The RN4020 module provides the capability to define their own private service or characteristics in the server role, as well as working with private service or characteristics in the client role.

All Bluetooth adopted public service/characteristics have a 16-bit short UUID. Conversely, all private service/characteristics have a 128-bit long UUID. Once the private service is enabled (see the “SS” command and its bitmap parameter), the private service/characteristic commands will be displayed in a help page (see the “H” command).

All private service/characteristic configuration commands begin with the letter “P”. The main function of those commands is to define the private service and its private characteristics. All definitions will be saved in NVM on the RN4020 module, which can be restored after a power cycle.

PC

The “PC” command sets the private characteristic. This command must be called after the private service UUID has been set (see the “PS” command). Calling this command adds one private characteristic to the private service at a time. Calling this command later will not overwrite the previous settings, but instead will add another private characteristic. This command is only effective if the private service bit is set (see the “SS” command and its bitmap parameter). The new settings will not take effect until a power cycle is performed.

Note: The RN4020 module supports up to 10 private characteristics.

Private characteristics with a property of notification or indication occupy two slots, whereas those characteristics without a property of notification or indication occupy one slot.

The “PC” command expects three or four parameters.

The first parameter is the 128-bit UUID for the private characteristic. There are many ways that a user can generate the 128-bit UUID with little possibility of conflict. For information, refer to the related Wikipedia page:
http://en.wikipedia.org/wiki/Universally_unique_identifier.

The second parameter is the 8-bit property bitmap of the characteristic. Refer to [Table 1-1](#) in [Chapter 1. “Introduction”](#) for the characteristic property.

The third parameter is an 8-bit value that indicates the maximum data size in bytes that the private characteristic holds. The real data size can be smaller. The maximum data size of a characteristic cannot exceed 20 bytes.

The optional fourth parameter is the 8-bit security flag bitmap of the characteristic. The bitmap is described in [Table 2-9](#). Note that if an authenticated read or write is defined, the authentication bit in the “SR” command must be set and the RN4020 module must have I/O capability for security keys. If this parameter is not provided, access to the characteristic requires no additional GATT security.

TABLE 2-9: SECURITY FLAGS OF CHARACTERISTIC

Name	Bitmap	Description
ENCR_R	0b00000001	Encryption required to read the characteristic
AUTH_R	0b00000010	Authentication required to read the characteristic
ENCR_W	0b00010000	Encryption required to write the characteristic
AUTH_W	0b00100000	Authentication required to write the characteristic

Example

```
PC,11223344556677889900AABBCCDDEEFF,1A,05
// Define a private characteristic with UUID
// 0x11223344556677889900AABBCCDDEEFF. It is readable, writable and
// could perform notification. Maximum data size for this
// characteristic is 5 bytes.
```

PS

The “PS” command sets the UUID of the private service. This command must be called before the “PC” command is called. This command is only effective if the private service bit is set (see the “SS” command and its bitmap parameter).

The effect of the “PS” command can only be shown after a valid “PC” command has been issued and after a power cycle.

The “PS” command expects one parameter, which is the 128-bit UUID for the private service. The UUID generation process is the same as that of private characteristics.

For information, refer to the related Wikipedia page:

http://en.wikipedia.org/wiki/Universally_unique_identifier.

Example

```
PS,010203040506070809000A0B0C0D0E0F
// Define a private service with UUID 0x010203040506070809000A0B0C0D0E0F
```

PZ

The “PZ” command clears all settings of the private service and the private characteristics. A power cycle is required to make the changes effective.

Example

```
PZ // Clear all private service and characteristics settings
```

2.2.5 Microchip MLDP Commands

2.2.5.1 MICROCHIP LOW-ENERGY DATA PROFILE (MLDP)

Built on top of BTLE GATT, Microchip developed the private service MLDP to simulate the operation of SPP.

To enable MLDP, the MLDP bit has to be set (see the “SR” command).

To run MLDP between two RN4020 modules, both devices must have the MLDP feature enabled.

The throughput of MLDP communication highly depends on the connection parameters, which decide the frequency of communication between a central device and a peripheral device (see the “T” command). High MLDP throughput requires frequent communication between the two devices and, therefore, consumes more power and shortens battery life. If battery life is the priority of the application, the expectation of MLDP throughput can be lowered.

Once MLDP is enabled, connection parameters are decided and an active link has been established between a central and peripheral device. Setting CMD/MLDP (pin 8) high enters MLDP mode. In MLDP mode, any data input from the UART module of the RN4020 will be sent wirelessly to the peer device. To exit MLDP mode, CMD/MLDP must be set low. After exiting MLDP mode, the RN4020 module will be back to the default Command mode.

To ensure data streams between the two RN4020 devices, both devices must enter MLDP mode. Conversely, the user has the option to enter MLDP mode automatically when receiving an MLDP message from the peer device by setting the MLDP_ENABLE_RX bit in the RN4020 features (see the “SR” command). When the MLDP_ENABLE_RX bit is set, MLDP mode can be initiated from one side of communication.

Besides being controlled by the CMD/MLDP pin, MLDP mode can also be entered by issuing the “I” command.

I

This command places the RN4020 module into MLDP simulation mode.

The “I” command is only effective if all of the following conditions are met:

- Central and peripheral devices have been connected
- MLDP mode is enabled using the “SR” command, which takes effect after a power cycle on both of the RN4020 devices

Once the “I” command is issued, the RN4020 module enters MLDP mode and all data through the UART will be wirelessly transmitted to the peer device. The only way to exit MLDP mode is to assert CMD/MLDP low.

Default

This command does not have any parameters.

Example

```
I // Enter MLDP mode
```

SE, <0-2>

The “SE” command sets the security mode for MLDP communications and expects one parameter.

If the parameter is ‘0’, no additional security is required.

If the parameter is ‘1’, MLDP data over the air will be encrypted. Bonding is required before the MLDP service starts.

If the parameter is ‘2’, MLDP data over the air will be authenticated. If this mode is enabled, the Enable Authentication bit must be set for the “SR” command, the RN4020 module must have I/O capability, and bonding must be done before the MLDP service starts.

Default

0

Example

```
SE,1      // Secure MLDP data over the air
```

2.2.6 RN4020 Scripting Commands

2.2.6.1 RN4020 SCRIPTING CAPABILITIES

In a typical setup, a host MCU via ASCII commands drives the RN4020 BLE module over the UART interface. However, for simple applications that do not require the I/O and computing functions of a host MCU, the RN4020 on-board I/O and scripting capabilities can be used. These scripts are ASCII commands that do not need to be compiled or processed before writing to the RN4020. The RN4020 firmware is not changed by writing, reading or executing the scripts. Scripts are written into the NVM of the RN4020 module, so a power cycle does not affect the script contents.

The scripting capability on the RN4020 module may be useful under the following circumstances:

- Reduced cost of the host MCU
- The user application uses proprietary service and characteristics
- The user application lends itself to the analog or digital ports that are available on the RN4020
- The user application logic is simple; instead of the RN4020, a peer device can perform interpolation of data
- A script cannot exceed 512 bytes and be less than 50 lines
- The scripting capability can also be used to lower the load of the host MCU and can be used to initialize settings and perform operations once a certain event is triggered

2.2.6.1.1 RN4020 Script Fundamentals

The main functionalities of scripting are achieved by executing ASCII commands, which are the same as those via the UART interface.

2.2.6.2 EVENT DRIVEN

A script is driven by events. Currently, there are 11 events defined. [Table 2-10](#) lists the supported events and their labels. All event scripts start with an event label, which is then followed by one or more logic operations or ASCII commands. Once an event is triggered, if an event label is defined, control is passed over to the script engine. The script engine begins executing the commands that are listed following the event label until the end of script or until another event label is encountered.

TABLE 2-10: LIST OF EVENTS AND EVENT LABELS

Event	Event Label
Power On	@PW_ON
Timer1 expired	@TMR1
Timer2 expired	@TMR2
Timer3 expired	@TMR3
Connected	@CONN
Disconnected	@DISCON
PIO4 (pin 13) Input Change to Low	@PIOL
PIO4 (pin 13) Input Change to High	@PIOH
High Priority Alert	@ALERTH
Low Priority Alert	@ALERTL
Alert Off	@ALERTO

2.2.6.3 COMMENTS

The RN4020 script engine handles each script line by line. Each line can start with multiple spaces or tabs and end with a return or line feed. Even though spaces are generally not supported between ASCII commands and their parameters, which is the same as commands through the UART, spaces or tabs are supported in assignment and logic expressions, as shown in the following example.

Comment lines can be added to the script. A comment line starts with the '#' character and lasts the whole line. The script engine will ignore the comment line and jump to the next script line once a comment line is detected.

The following script line is treated as a comment:

```
# This is an example of a comment line
```

2.2.6.4 VARIABLES

The RN4020 script engine defines two variables: \$VAR1 and \$VAR2. Variable names are case sensitive. Using the '=' operator, the value of the variables can be assigned to a constant value, or a value that is returned by an ASCII command. For instance, the following script line assigns the value 0x1234 to the variable \$VAR1:

```
$VAR1 = "1234"
```

Similarly, the following script line assigns the reading of AIO1 to the variable \$VAR2:

```
$VAR2 = @I,1
```

After assigning a value, variables can then be used in an ASCII command. For instance, the following ASCII command assigns the value of the variable \$VAR1 to the server characteristic handle 0x0019.

```
SHW,0019,$VAR1
```

The range of variables can be defined so that if a variable value is not in the defined range, the corresponding ASCII command(s) with variables would not be executed.

The range of a variable can be a single condition, such as the following script line, which defines that the variable \$VAR1 must be larger than 0x0100.

```
$VAR1 > "0100"
```

The variable range can also be defined by two conditions using the Boolean operators "&&" for logical AND, and "||" for logical OR. In the following script lines, \$VAR1 is defined to be valid in the range between 0x0050 and 0x0120, while \$VAR2 is defined to be either larger than 0x0100 or less than 0x0020.

```
$VAR1 > "0050" && $VAR1 < "0120"  
$VAR2 > "0100" || $VAR2 < "0020"  
$VAR1 = @I,0  
$VAR2 = @I,1  
SHW,0019,$VAR1  
SHW,0021,$VAR2
```

In the first two lines of the script, the variable ranges are defined. The following two script lines read the values of analog port AIO0 and AIO1, respectively, and assigns them to the two variables. If the read of AIO0 is between the values of 0x0050 and 0x0120, the value is assigned to server characteristic handle 0x0019; otherwise, no value is assigned to the handle. Similarly, if the read of AIO1 is larger than 0x0100 or less than 0x0020, the value is assigned to server characteristic handle 0x0021; otherwise, no value is assigned to the handle.

Currently, only two single character logic operators, ">" and "<", are supported.

2.2.6.4.1 Handle Association

An I/O port can be associated with the handle of a server characteristic. Once the handle receives requests from a peer device to read or write, the I/O port is read or written, respectively, without further instruction. The analog port and four digital ports can be associated with a handle. The associated handle can be identified by the preceding identifier "%".

For instance, the following script line associates server characteristic handle 0x0021 with a read operation of analog port AIO2, so whenever the peer device wants to read handle 0x0021, AIO2 is read and the value will be returned to the peer device.

```
%0021 = @I,2
```

The following script line associates server characteristic handle 0x0023 with a write operation of analog port AIO0, so whenever the peer device wants to write to handle 0x0023, the written value from the peer device will be used to set the output voltage on AIO0.

```
@O,0,%0023
```

In the same manner, a characteristic value can be associated with, or linked to, one or more ports using "|I" or "|O". For example, the following command maps PIO1 and PIO7 to characteristic handle 0x0021 for reading:

```
%0021 = |I,09
```

The following command maps PIO2 and PIO3 to handle characteristic 0x0023 (hex) for writing:

```
|O,06,%0023
```

NOTICE

Association with digital I/O ports can be either read and/or write; however, a read or write association can only be done once. A subsequent read association will overwrite the previous read. The same rule applies to write association, but a read association does not overwrite a write association.

2.2.7 RN4020 Script Commands

The following ASCII commands over the UART were developed to support the scripting functionality on the RN4020 module.

LW

The “LW” command lists the current script that is loaded in the RN4020 module. After all script lines are output, the string “END” will be output to the UART.

Default

The “LW” command has no parameters.

Example

```
LW          // List the complete script loaded in the RN4020 module
```

WC

The “WC” command clears the script, if any, that is loaded in the RN4020.

Default

The “WC” command has no parameters.

Example

```
WC          // Clear the script loaded in the RN4020 module
```

WP

The “WP” command stops script execution.

Default

The “WP” command has no parameters.

Example

```
WP          // Stop running the script
```

WR, <0 - 9>

The “WR” command starts script execution. If no parameter is provided, the script runs normally by starting a @PW_ON event. When a parameter in the range of 0 to 9 is provided, the script starts running the corresponding event in Debugging mode. When the script is running Debugging mode, all variables assigned and any ASCII commands executed would be output to the UART for debugging purposes by the developer.

The input parameters and their associated events are listed in [Table 2-11](#).

TABLE 2-11: “WR” COMMAND INPUT PARAMETERS AND ASSOCIATED EVENTS

Input Parameter	Event
0	@PW_ON
1	@TMR1
2	@TMR2
3	@CONN
4	@DISCON
5	@PIOL
6	@PIOH
7	@ALERTH
8	@ALERTL
9	@ALERTO

Default

Not applicable.

Example

```
WR,1          // Starts script by entering @TMR1 event
```

WW

The “WW” command enters Script Input mode. When in Script Input mode, the script can be input through the UART line by line. Once all script lines are input, press the “ESC” key to exit Script Input.

Default

The “WW” command has no parameters.

Example

```
WW          // Enter script input mode
```

2.2.8 Remote Command

The RN4020 module has the capability of executing an ASCII command remotely from connected devices. This remote command feature is built on top of MLDP, so it is a prerequisite to support MLDP before using the remote command feature.

The remote command feature enables users to execute commands on connected peer devices. The command is sent to the connected remote device, executed at the remote device, and the result is sent back to the local device. Since the UART output rate is usually much higher than the BLE transmission rate, if the output data (such as the “H” or “LS” command, etc.) exceeds the buffer size (128 bytes), the local device may only receive whatever is stored in the buffer.

The remote command capability provides a mechanism for another Bluetooth device running in Central mode to send commands to a remote RN4020 module in Peripheral mode. A host device can use a remote command to gain access to the remote device and access and control all of its analog or digital I/O ports. All application logic is performed on the host device. Therefore, no programming or application logic needs to be run on the remote device. To summarize, the remote command function allows the central host to connect to any RN4020 peripheral device and invoke commands.

!, <0, 1>

The “!” command enables the remote command feature. This command is only effective under the following three conditions:

- The local and remote devices both support the MLDP feature
- The Enable Remote Command bit of the remote device was set using the “SR” command
- The two devices are connected

The “!” command expects one parameter, either ‘1’ or ‘0’.

If the input parameter is ‘1’, the Remote Command mode is enabled, the device enters Remote Command mode automatically, and the message “RMT_CMD” is sent from the remote device to indicate the start of the remote command session.

To exit Remote Command mode, the local device sets the CMD/MLDP pin low, and then issues the command “!,0”. The remote device will then exit Remote Command mode and return to local command mode.

2.3 DEVICE FIRMWARE UPGRADE

The Device Firmware Upgrade (DFU) feature allows the RN4020 module to upgrade its firmware in the field. As with any DFU process, a firmware upgrade should be handled carefully to avoid unrecoverable damage to the device.

The RN4020 module supports two methods for performing a DFU:

- A wired solution through the UART
- A wireless solution Over-the-Air (OTA)

Both solutions provide firmware integrity support. If an upgrade fails for any reason, keep the RN4020 module alive and try to recover by applying the DFU process again.

The following conditions must be met when the RN4020 module performs a DFU through the UART:

- UART hardware flow control (RTS/CTS) must be used
- No UART communication other than streaming the DFU image
- No RF communication attempts. All other operations during a DFU period should be avoided

The following conditions must be met when the RN4020 performs DFU through OTA:

- Only a one-to-one connection is allowed between the device whose firmware is to be updated and the device that provides the update image
- Avoid RF interference whenever possible
- The module that is streaming the image to the remote device must have UART hardware flow control enabled

See [Section 2.3.1 “DFU Commands”](#) for a description of the actions that occur during a DFU.

2.3.1 DFU Commands

~, <1, 2>

The “~” command places the device into Device Firmware Service mode. To use this command, it is mandatory to enable the UART flow control. The “~” command expects one input parameter.

If the input parameter is ‘1’, DFU mode is set for the upgrade to be handled through the UART. The message “DFU” will be output and the RN4020 module waits for the DFU image to be sent through the UART. The user must then stream the signed Microchip RN4020 image to the UART. If a terminal emulator is used, it is recommended to use a feature such as “send file” or something similar.

If the input parameter is ‘2’, DFU mode is set for the upgrade to occur OTA. A valid BLE connection must be established before the command “~,2” can be issued from the device that will send the DFU image. Both ends of the connection must support MLDP, and ENABLE OTA must be set by the “SR” command.

Once both devices enter OTA mode, the message “OTA” is sent to the UART of the device that is to send the DFU image. The device sending the DFU image can then begin streaming the valid and signed Microchip RN4020 image. If a terminal emulator is used, it is recommended to use the “send file” feature to upload the DFU image. Visit <http://www.microchip.com/RN4020> for the latest DFU images.

Once the DFU has completed and is verified as successful, the message “Upgrade OK” is displayed and the RN4020 module reboots to use the new firmware. If the DFU is not successful, the message “Upgrade Err” is displayed and both RN4020 modules remain in OTA mode. Users should NOT reset or power down either module, but instead try to stream the valid and signed Microchip RN4020 image again until the upgrade is successful.

Chapter 3. Application Examples

This chapter provides application examples for the RN4020 module. The following topics are included:

- [Demonstration with a Smart Device](#)
- [Connecting Two RN4020 Modules](#)
- [MLDP Demonstration](#)
- [RN4020 Scripting Demonstration](#)

The Bluetooth Low Energy capabilities of the RN4020 module can be demonstrated either between the RN4020 and a third-party Bluetooth Smart/Smart Ready device (such as a smartphone or tablet), or between two RN4020 modules.

3.1 DEMONSTRATION WITH A SMART DEVICE

In this section, a step-by-step procedure is detailed which demonstrates how the RN4020 module can interface with a smartphone or tablet device. To support BTLE, the following hardware and software are required:

- Bluetooth Low Energy enabled smart phone or tablet
- Bluetooth Low Energy Browser APP - BTLE BROWSER APP (see the **Note**)
- Terminal emulator connected to the RN4020 UART for access to the command interface

<p>Note: The following diagrams show a generic version Smartphone BTLE Service Browser APP, which is referred to as the BTLE BROWSER APP.</p>
--

3.1.1 Setup

Before connecting an RN4020 module to a smartphone device, users may need to set up the RN4020 module as follows:

1. Set the WAKE_SW pin high to enter Command mode.
2. Open a terminal emulator that connects to the serial port of the RN4020 module with the following parameters:
 - Baud rate: 115200
 - Data bits: 8
 - Parity: None
 - Stop bits: 1
3. Issue the “+” command to turn on echo.
4. Issue the command `SF,1` to reset to the factory default configuration.
5. Issue the command `SS,C0000000` to enable support of the Device Information and Battery services.
6. Issue the command `SR,00000000` to set the RN4020 module as a peripheral.
7. Issue the command `R,1` to reboot the RN4020 module and to make the new settings effective.

8. After the RN4020 module has powered up and "CMD" is displayed on the terminal emulator, issue the "LS" command to display the current services that the RN4020 module enumerates and supports in the server role. The output of the "LS" command will be as follows:

```
180A
 2A25,000B,V
 2A27,000D,V
 2A26,000F,V
 2A28,0011,V
 2A29,0013,V
 2A24,0015,V
180F
 2A19,0018,V
 2A19,0019,C
END
```

3.1.2 Running the Demonstration

1. On the terminal emulator, enter the "A" command to start advertisement.
2. Launch your BTLE BROWSER APP.
3. Configure the BTLE BROWSER APP to be the "Central" device and start active scan for BTLE peripherals. After the scan is completed, the RN4020 module will be listed as "RN4020-xxxx", where "xxxx" is the first two bytes of the Bluetooth device address. The RN4020 module is now ready to be connected.

FIGURE 3-1: DISCOVERING THE RN4020 MODULE

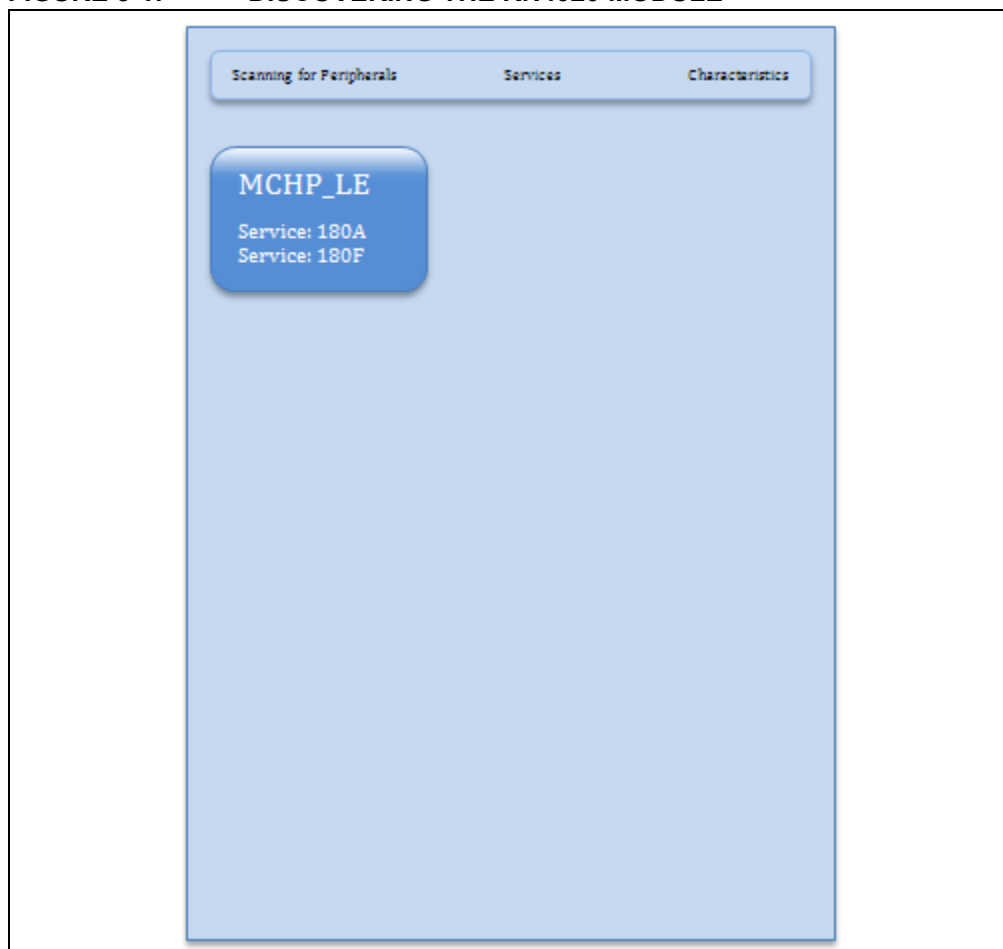

- From BTLE BROWSER APP, issue the command to connect to the RN4020. The BTLE BROWSER APP will list the handle of the services, service “180A” and “180F”, and the UUIDs of the Device Information and Battery Services, respectively, will be seen.
- Opening the service “180A” will display six additional UUIDs for the characteristics of the Device Information service. Access each of the six characteristic UUIDs to display the characteristic window. Invoke the read command in the BTLE BROWSER APP to read the current settings of those characteristics. [Figure 3-2](#) shows an example of the application displaying the Model Number String of RN4020 in the Device Information Service.

FIGURE 3-2: READING THE MODEL NUMBER STRING FROM THE DEVICE INFORMATION SERVICE

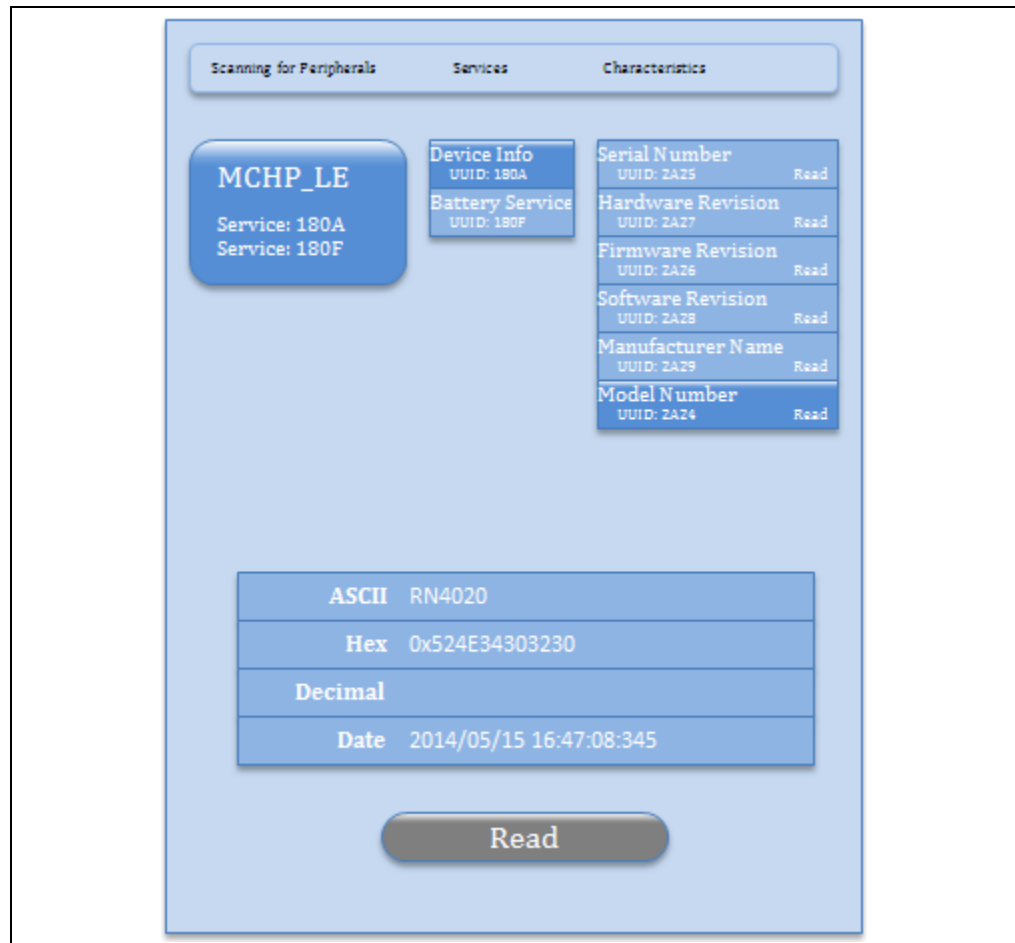

- Read UUID “180F” to show one characteristic Battery Level with UUID “2A19”. Reading the “2A19” characteristic shows this characteristic’s property: readable and notification can be started.

RN4020 Bluetooth Low Energy Module User's Guide

- Return to the terminal emulator to control the RN4020 directly to set the Battery Level to 99% using either of the following two commands:

```
SUW,2A19,63  
SHW,0018,63
```

The first command sets the value of characteristic Battery Level to be 99 (0x63) by addressing its UUID 0x2A19.

The second command sets the value of characteristic Battery Level to be 99 (0x63) by addressing its handle 0x0018. The match between handle and UUID can be found by command “LS”. The handle value for each characteristic stays the same for the same set of server service settings. As long as the supported server services are not changed by command “SS”, the handles of the characteristics stay the same.

- Read the characteristic identified by UUID 0x2A19. The returned value will show 63 in hexadecimal and 99 in decimal, as shown in [Figure 3-3](#).

FIGURE 3-3: READING BATTERY LEVEL IN BATTERY SERVICE

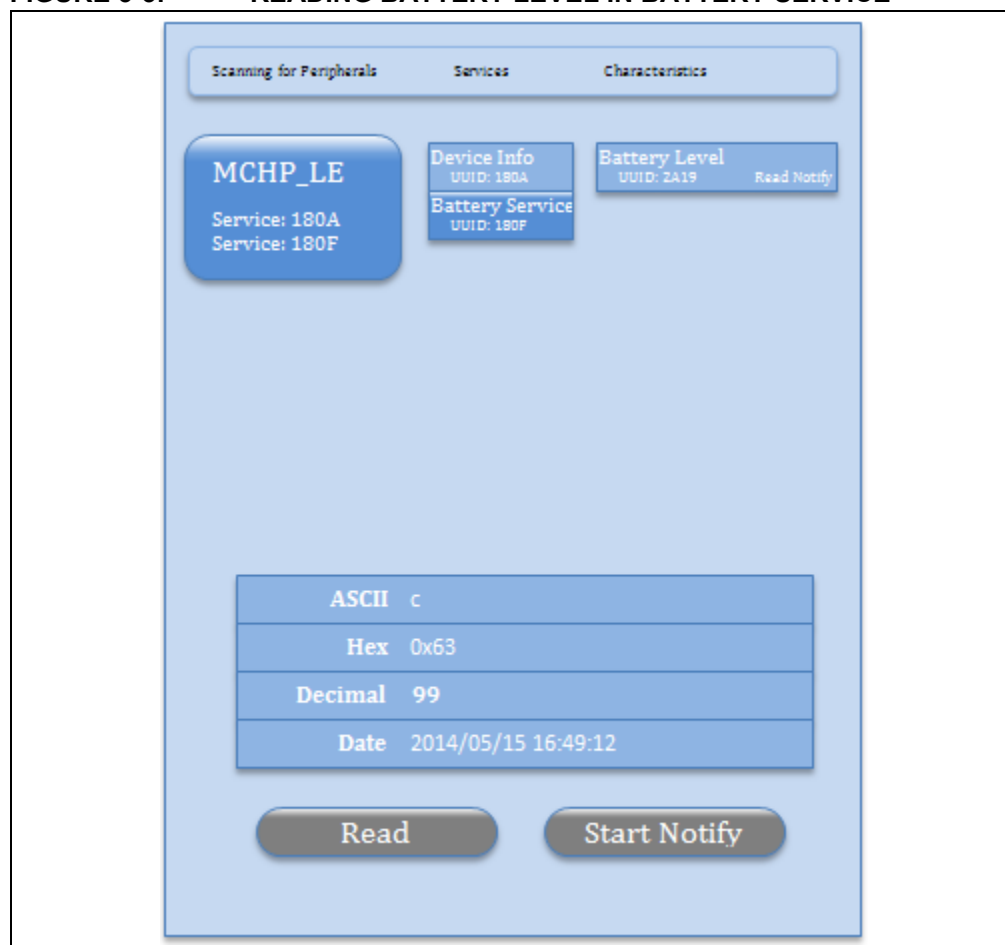

The application can also start notification on the Battery Level characteristic by tapping the “Start Notify” button. On the RN4020 side, a notification will output to the screen and display as follows:

```
WC,0019,0100
```



This output means the application tried to write the two byte value, 0x0001 (little endian over air makes it 0100), to the configuration handle of the Battery Level characteristic with the UUID 0x2A19 in the Battery Service with the UUID 0x180F, effectively enabling notification for this characteristic. Refer to *Table 3.11: “Client Characteristic Configuration bit field definition”* in *Volume 3, Part G, Section 3.3.3.3 “Client Characteristic Configuration”* of *“Bluetooth Core Specification v4.1”*, for details.

9. Update the battery level to 50% on the RN4020 module by entering either of the following two commands:

```
SUW, 2A19, 32  
SHW, 0018, 32
```

After issuing either of the two commands, users will see that the characteristic value of UUID 2A19 in the BTLE BROWSER APP automatically updates to 0x32 (50 decimal). This is because with an active notification, any update to the value of a characteristic on the server side will be notified to the client side. See [Figure 3-4](#) for an example.

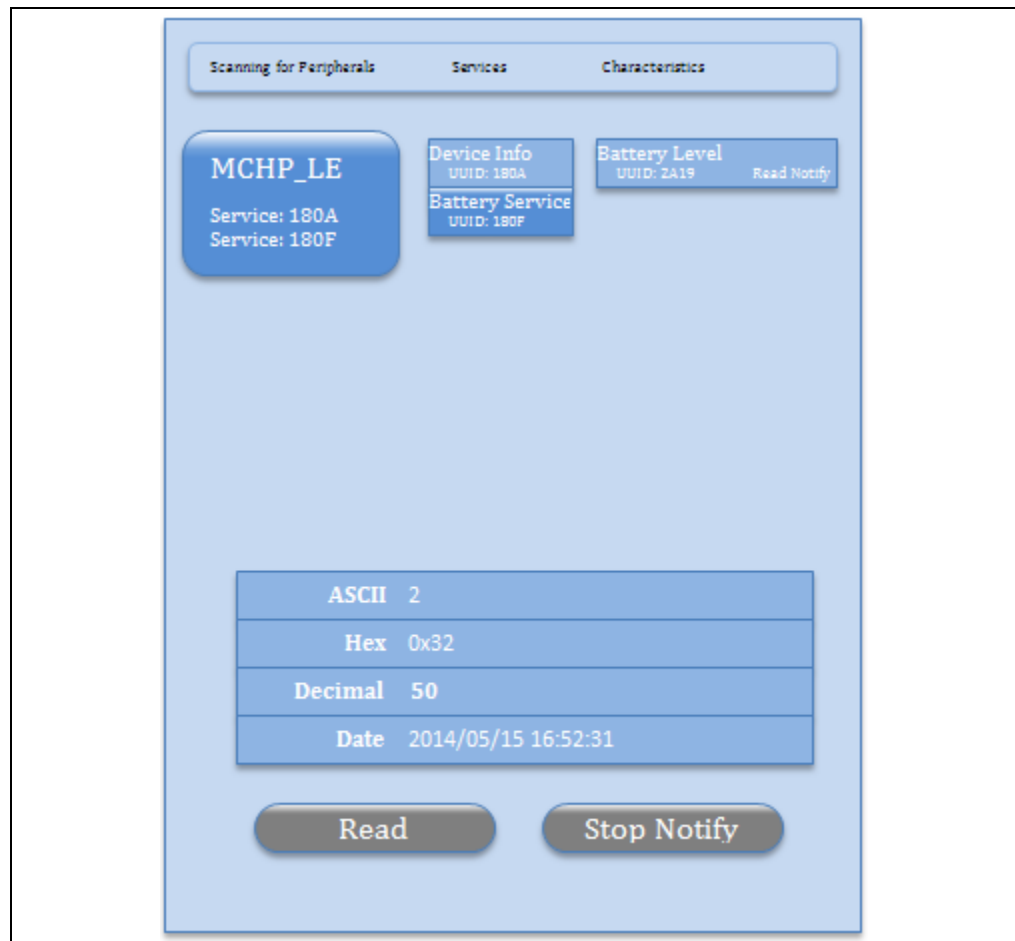
FIGURE 3-4: NOTIFICATION RESULT OF BATTERY LEVEL



If desired, the private services that can be defined by the user on the RN4020 module can be tested. The command procedures and their descriptions are shown in [Example 3-1](#).

RN4020 Bluetooth Low Energy Module User's Guide

EXAMPLE 3-1: USER-DEFINED PRIVATE SERVICES

```
SS,C0000001 //Enable private service support
PZ          // Clear the current private service and characteristics
PS,11223344556677889900AABBCCDDEEFF
// Set private service UUID to be 0x11223344556677889900AABBCCDDEEFF

PC,010203040506070809000A0B0C0D0E0F,02,05
// Add private characteristic 0x010203040506070809000A0B0C0D0E0F to
// current private service. The property of this characteristic is 0x02
// (readable; see Table 1-1) and has a maximum data size of 5 bytes

PC,111213141516171819101A1B1C1D1E1F,18,02
// Add private characteristic 0x111213141516171819101A1B1C1D1E1F to
// current private service. The property of this characteristic is 0x18 (writable
// and could notify; see Table 1-1) and has a maximum data size of 2 bytes.

U          // Unbond to make device discoverable
R,1       // Reboot RN4020 to make the changes effective
+         // Enable echo
LS        // list the services on server side. Private service and
// characteristics could be found in the list
```

The following results will be returned for the server services:

```
180A
  2A25,000B,V
  2A27,000D,V
  2A26,000F,V
  2A28,0011,V
  2A29,0013,V
  2A24,0015,V
180F
  2A19,0018,V
  2A19,0019,C
11223344556677889900AABBCCDDEEFF
  010203040506070809000A0B0C0D0E0F,001C,02,05
  111213141516171819101A1B1C1D1E1F,001E,08,02
  111213141516171819101A1B1C1D1E1F,001F,10,02
END
```

Since the service settings were changed, but the previous settings are still in the smartphone/tablet's cache, rebooting the smartphone/tablet device may be necessary to clear the device cache. After power cycling and launching the BTLE BROWSER APP, the private service and characteristics will be seen. Figure 3-5 shows that the BTLE BROWSER APP has discovered the private services that were just defined.

FIGURE 3-5: PRIVATE SERVICES DISCOVERED AFTER POWER CYCLE



Just as with public services, such as Device Information and Battery service, these characteristics can read, write and get notification by issuing commands as follows:

```
SUW,010203040506070809000A0B0C0D0E0F,1234
// Set value 0x3412 to characteristic
// 0x010203040506070809000A0B0C0D0E0F

SHW,001C,5678
// Set value 0x7856 to handle 0x001C, which is associated
// with characteristic 0x010203040506070809000A0B0C0D0E0F
```

The application can then read the value of characteristic 0x010203040506070809000A0B0C0D0E0F, as shown in [Figure 3-6](#).

FIGURE 3-6: READING THE PRIVATE CHARACTERISTIC



The BTLE BROWSER APP can also write or start notification on characteristic 0x111213141516171819101A1B1C1D1E1F. The effect is the same as operating on a public characteristic. The only difference to the RN4020 module is that the public characteristic has a short 16-bit UUID, while the private characteristic has a long 16-byte UUID.

Figure 3-7 shows writing the value 0x3412 (little endian) to the private characteristic 0x111213141516171819101A1B1C1D1E1F from the application. On the terminal emulator of the RN4020 module, the following status message will appear, which means the value of characteristic 0x111213141516171819101A1B1C1D1E1F (with handle 0x001E) has been written as 0x3412.

```
WV,001E,1234
```

FIGURE 3-7: WRITING VALUES TO PRIVATE CHARACTERISTICS



Notification on a private characteristic can also be enabled. The RN4020 module will notify the host of the start of notification by the following status message, which means the configuration of characteristic 0x11223344556677889900A0B0C0D0E0F has been written as 0x0001 (little endian); therefore, the notification has been started.

```
WC,001F,0100
```

Once the notification has been started, the value of the private characteristic is updated from the RN4020 module, and the updated value is displayed in the BTLE BROWSER APP.

Use the following commands to update the value of the private characteristic:

```
SUW, 11223344556677889900A0B0C0D0E0F,AB90
// Set value 0x90AB to characteristic
// 0x11223344556677889900A0B0C0D0E0F

SHW,001E,EFCF
// Set value 0xCDEF to handle 0x001E, which is associated
// with characteristic 0x11223344556677889900A0B0C0D0E0F
```

The value of the private characteristic 0x11223344556677889900A0B0C0D0E0F will be updated automatically to 0x90AB and 0xCDEF, respectively, as shown in [Figure 3-8](#).

FIGURE 3-8: NOTIFICATION TO PRIVATE CHARACTERISTIC



3.2 CONNECTING TWO RN4020 MODULES

BTLE functionality can be demonstrated between two RN4020 modules.

Note: In this demonstration, one RN4020 module must act in a central role and the other in a peripheral role. In addition, the services as server and client roles will also be demonstrated.

To demonstrate module-to-module connectivity, two RN4020 modules are required. For this demonstration, the RN4020 Bluetooth Low Energy PICtail™/PICtail Plus Daughter Board is recommended.

3.2.1 Configure the First Device (Module A)

The first RN4020 module, which is referred to as Module A, must be configured to be in a central role. The following commands are issued to configure the device:

1. Pull WAKE_SW high to enter Command mode. On the daughter board, this is the default state.
2. Open a terminal emulator that connects to the serial port of Module A with the following parameters:
 - Baud rate: 115200
 - Data bits: 8
 - Parity: none
 - Stop bits: 1
 - Flow control: hardware
3. `+ // turn echo on`
4. `SF,1 // factory reset`
5. `SS,C0000000 // Support Device Info and Battery as server`
6. `SR,92000000 // Set device as central, support MLDP and enable
// UART flow control`
7. `R,1 // reboot to make changes effective`

3.2.2 Configure the Second Device (Module B)

The second RN4020 module, which is referred to as Module B, must be configured to be in a peripheral role. The following commands are issued to configure this device:

1. Pull WAKE_SW high to enter Command mode. On the daughter board, this is the default state.
2. Open a terminal emulator that connects to the serial port of Module A with the following parameters:
 - Baud rate: 115200
 - Data bits: 8
 - Parity: none
 - Stop bits: 1
 - Flow control: hardware
3. `+ // turn echo on`
4. `SF,1 // factory reset`
5. `SS,30000000 // Support Heart Rate and Health Thermometer
// services as server. Notice that server services
// in Module B overlap client services in Module A`
6. `SR,32000000 // Set device as peripheral with automatic
// advertisement, and support for MLDP and flow
// control features`
7. `R,1 // Reboot the device to make the changes effective`

3.2.3 Connecting the Two Devices

When Module B is powered up, it automatically starts advertisement since the automatic advertisement feature is enabled with the “SR” command. Module A can then try to connect to Module B using the “F” command:

```
F // Start scan
```

The scan result will appear quickly as follows, where the three elements are the MAC address, the MAC address type, and the device name, respectively.

```
00035B0358E6,0,MCHP-LE,-50
```

Issue an “X” command followed by an “E” command to stop scanning and then establish a connection:

```
X // Stop scanning
E,0,00035B0358E6 // Try to establish connection with device of
// public MAC address 0x00035B0358E6
```

3.2.4 Checking Server and Client Services

Once connected, the message “Connected” will appear on the terminal emulators of both devices. Then we can check the server and client services on both modules.

From Module A, issue the following commands:

```
LS // List server services
LC // List client services
```

The server and client services for Module A are listed in [Table 3-1](#).

TABLE 3-1: MODULE A SERVER AND CLIENT SERVICES

Server Services	Client Services
180A	180D
2A25,000B,V	2A37,000B,00
2A27,000D,V	2A37,000C,10
2A26,000F,V	2A38,000E,02
2A28,0011,V	2A39,0010,08
2A29,0013,V	1809
2A24,0015,V	2A1C,0013,00
180F	2A1C,0014,20
2A19,0018,V	2A1D,0016,02
2A19,0019,C	END
END	

From Module B, issue the following commands:

```
LS // List server services
LC // List client services
```

The server and client services for Module B are listed in [Table 3-2](#).

TABLE 3-2: MODULE B SERVER AND CLIENT SERVICES

Server Services	Client Services
180D	180A
2A37,000B,V	2A25,000B,02
2A37,000C,C	2A27,000D,02
2A38,000E,V	2A26,000F,02
2A39,0010,V	2A28,0011,02
1809	2A29,0013,02
2A1C,0013,V	2A24,0015,02
2A1C,0014,C	180F
2A1D,0016,V	2A19,0018,02
END	2A19,0019,10
	END

Users will notice that the server services on Module A match the client services on Module B and vice versa. Therefore, the data exchange between Module A and Module B can follow the client-server model where the server maintains the data and the client has access to the data.

3.2.5 Setting the Battery Service

From Module A, the Battery Service is a server service, so the battery level can be set to 100% by either of the following commands as server services access:

```
SUW,2A19,64 // Set Battery Level (UUID 0x2A19) to be 100
SHW,0018,64 // Set Battery Level (handle 0x0018) to be 100
```

From Module B, the Battery Service is in a client role, so the battery level can be read from the server service on Module A using the following commands as client access:

```
CURV,2A19
CHR,0018
```

Both commands will return the value of Battery Level characteristic 0x2A19 to be 100 as follows:

```
R,64
```

The output means the characteristic read returns data of 1 byte in length and a value of 0x64.

From Module B, notification can be started by issuing either of the following commands:

```
CUWC,2A19,1
CHW,0019,0100
```

The client service command, “CUWC”, writes a configuration of UUID 0x2A19 to be notification enabled. The client service command, “CHW”, writes value 0x0001 (little-endian format) to handle 0x0019, which corresponds to the characteristic UUID of 0x2A19. According to *Table 3.11: “Client Characteristic Configuration bit field definition”* in *Volume 3, Part G, Section 3.3.3.3 “Client Characteristic Configuration”* of *“Bluetooth Core Specification 4.1”*, the value 0x0001 means start notification.

Once notification is successfully started, Module A will notify the host of the event with the following format:

```
WC,0019,0100
```

This means the configuration for primary service 0x180F (Battery Service), characteristic 0x2A19 (Battery Level), has been written by 2 bytes with value 0x0001 (little endian format), or means notification has started. If the Battery Level characteristic had a set value before, a notification will be sent to Module B automatically.

RN4020 Bluetooth Low Energy Module User's Guide

Once notification is successfully started, and the Battery Level characteristic has been set to the previous value, a notification will be received by Module B with the following format:

```
Notify,0018,64
```

This means that the value of characteristic 0x2A19 (Battery Level) in the primary service 0x180F (Battery Service) has been updated to 0x64.

After notification starts, the value change on the Battery Level on Module A will be updated on Module B. Use either of the following commands on Module A and check the automatic updates on Module B.

```
SUW,2A19,5A // Set Battery Level to be 90% on Module A  
SHW,0018,50 // Set Battery Level to be 80% on Module A
```

Similar operations can be performed on Heart Rate or Health Thermometer services, where Module B sets the values and Module A reads values.

3.3 MLDP DEMONSTRATION

Once access of characteristics in public services have been verified, the MLDP service can be started. The MLDP service is built on top of the private service, but acts transparently to the user. To use the MLDP service between two RN4020 devices, both devices must enable MLDP with the proper parameters using the “SR” command. MLDP mode can only be started when two RN4020 modules both have MLDP enabled and are connected together.

To start MLDP mode, simply assert the CMD/MLDP pin to be high. The RN4020 module will output “MLDP” to indicate the start of MLDP mode. Once in MLDP mode, any data from the UART will be sent to the peer device. When receiving MLDP data from the peer, if the AUTO_MLDP_DISABLE feature is not enabled (see the “SR” command), the RN4020 module will automatically enter MLDP mode; otherwise, all data will be ignored until CMD/MLDP is set high to enter MLDP mode.

From Module A, assert CMD/MLDP to be high and wait until “MLDP” is output to the terminal emulator. Provided Module B shows “MLDP”, anything typed on the terminal emulator of Module A Type will appear on the terminal emulator of Module A. Users can also try to type on the terminal emulator of Module B, which shows the same output on the terminal emulator of Module A.

To exit MLDP mode, set CMD/MLDP to be low and “CMD” will appear on the terminal emulator to indicate that the RN4020 module is back in Command mode. Next, set CMD/MLDP to be low on Module B (WAKE_HW and CMD/MLDP have weak pull down resistors, so they will stay low if not pulled high). Then, disable the notification on Battery Level with either of the following commands:

```
CHW,0019,0000  
CUWC,2A19,0
```

On Module A, the status change will be notified to the host. However, Module A is currently in MLDP mode and only output MLDP data is sent to the UART. Instead, PIO2 will be set high (the red LED (MLDP_EV) illuminates on the RN4020 PICtail Daughter Board) to indicate the pending status message. Once CMD/MLDP is set low to enter Command mode, the status message will be output to the UART. The maximum status message that can be held is 256 bytes.

3.4 RN4020 SCRIPTING DEMONSTRATION

In this section, a step-by-step guide is provided to demonstrate the capability of scripting on the RN4020 Bluetooth Low Energy PICtail™/PICtail Plus Daughter Board.

3.4.1 Setting Up Private Service and Characteristics

The scripting function works best with the private service and characteristics. The main input/output peripherals in scripting are the analog or digital ports. The predefined data format of public services and characteristics may not always work with the reading or output of RN4020 ports. However, private service and characteristics can define the data format freely. Therefore, a peer device of the BLE connection is able to take over the data interpolation functionality without involvement of the device that runs scripts.

The following UART ASCII commands set up the private service and characteristics:

```
+ // Echo on
SF,1 // Factory Reset
SS,00000001 // Enable private service
SR,00000000 // Set as Peripheral
PZ // Clean private Service
PS,123456789012345678901234567890FF // Set private service UUID
PC,12345678901234567890123456789011,12,02 // Set private
// characteristic to be readable, notifiable and 2 bytes
// in length
PC,12345678901234567890123456789022,02,02 // Set private
// characteristic to be readable and 2 bytes in length
R,1 // Reboot
```

After rebooting, the “LS” command can be used to check the server characteristics:

```
123456789012345678901234567890FF
12345678901234567890123456789011,000B,02,02
12345678901234567890123456789011,000C,10,02
12345678901234567890123456789022,000E,02,02
```

3.4.2 Script Input

To start writing the script, it must first be cleared and Script Input mode is entered using the following commands:

```
WC // Clean script
WW // Enter script input mode
```

Next, input the following script. After entering the script, press the “ESC” key to exit.

```
@PW_ON
# start advertisement
A
# define range of variable $VAR1
$VAR1 < "0300"
# associate handle 0x000E to reading of AIO2
%000E = @I,2

@CONN
# set timer 1 to be around 5 seconds
SM,1,00500000

@TMR1
# read AIO0
$VAR1 = @I,0
# set handle 0x000B to the AIO0 value
SHW,000B,$VAR1
# restart timer
SM,1,00500000
```

After powering on, event @PW_ON is generated. The script will first start advertisement. Then, it defines the range of \$VAR1 to be less than 0x0300. Finally, it associates handle 0x000E to the analog port AIO1, which is the temperature sensor.

Once connection is established, event @CONN is generated. The script sets up Timer1 to expire in approximately five seconds.

Once Timer1 is expired, event @TMR1 is generated. AIO0 is read and the value is assigned to \$VAR1. If the read is within the predefined range (less than 0x0300), the value is written to handle 0x000B; otherwise, handle 0x000B is not updated.

If desired, the command "WR,<0-9>" can be used to debug the script.

3.4.3 Running the Script

Run the script by enabling the script after power on using the following commands:

```
SR,01000000 // Run script after power on
R,1 // Reboot
```

After rebooting, the script will be running. Users can open the Bluetooth access application from a smartphone or tablet and connect to the RN4020 module. Click the characteristic 0x12345678901234567890123456789011 and start notify.

Every five seconds, AIO0 (the light sensor) will be read. If the AIO0 value matches the rule for \$VAR1 < "0300", the value of the characteristic will be updated every five seconds.

When the light sensor is exposed to bright light, the reading of AIO0 is usually higher than 0x0400; therefore, the value to handle 0x000B is not updated. If the light sensor is blocked from bright light, the AIO0 reading may be lowered to less than 0x0300; therefore, the value will be updated on the Bluetooth access application.

Conversely, for characteristic 0x12345678901234567890123456789022, users can read its value using a BTLE BROWSER APP. Since the corresponding handle 0x000E has been associated with AIO2, a read of handle 0x000E will return the reading of AIO2 without involvement of a host MCU.

In this demonstration, the script runs the RN4020 module and performs tasks independently. It shows that for a simple application like this, the RN4020 module can run stand-alone without the need for a host MCU.

Appendix A. PICtail™ Daughter Board Schematics

This appendix provides the schematic diagrams for the PICtail Daughter Board and includes the following figures:

- **Figure A-1: “RN4020 Module”**
- **Figure A-2: “PIC18LF25K50-I/ML Device”**
- **Figure A-3: “28-pin and 30-pin PICtail™ Connectors”**
- **Figure A-4: “RN4020 Module Breakout Pins”**
- **Figure A-5: “Status LEDs”**
- **Figure A-6: “Voltage Regulator”**
- **Figure A-7: “Decoupling Capacitor for the PIC18LF25K50-I/ML Device”**
- **Figure A-8: “Test Switch”**
- **Figure A-9: “ICSP™ Connector”**

FIGURE A-1: RN4020 MODULE

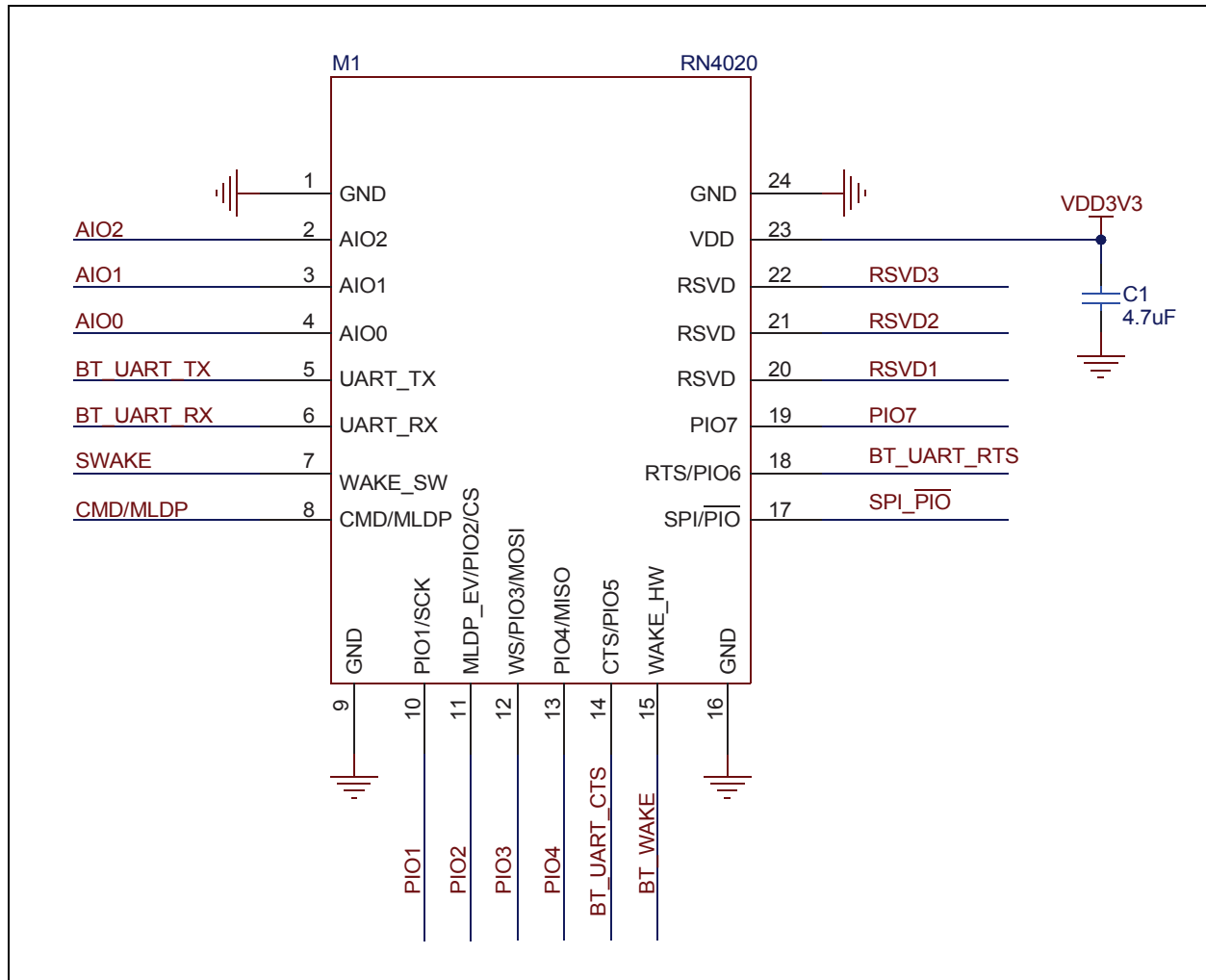

FIGURE A-2: PIC18LF25K50-I/MML DEVICE

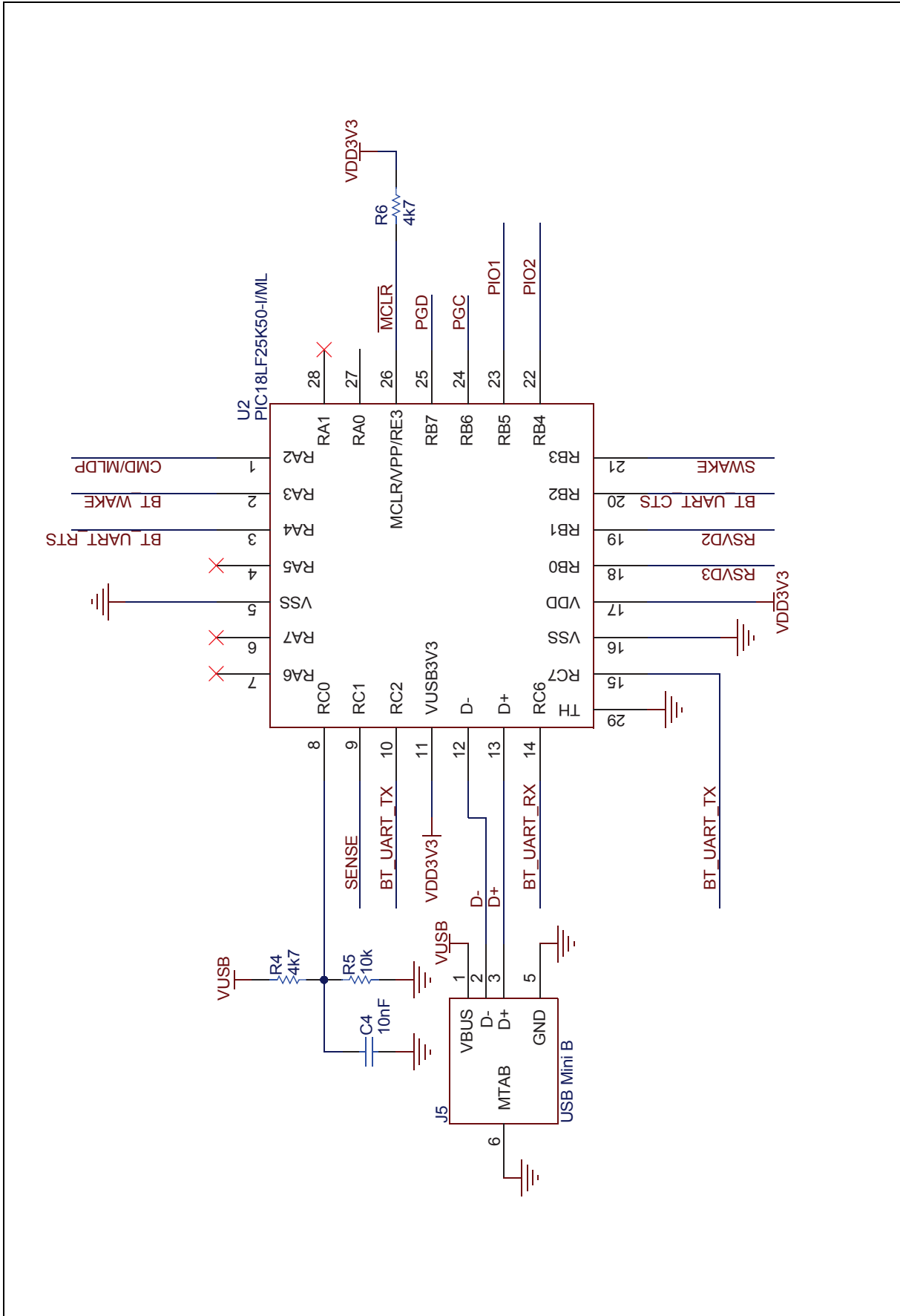
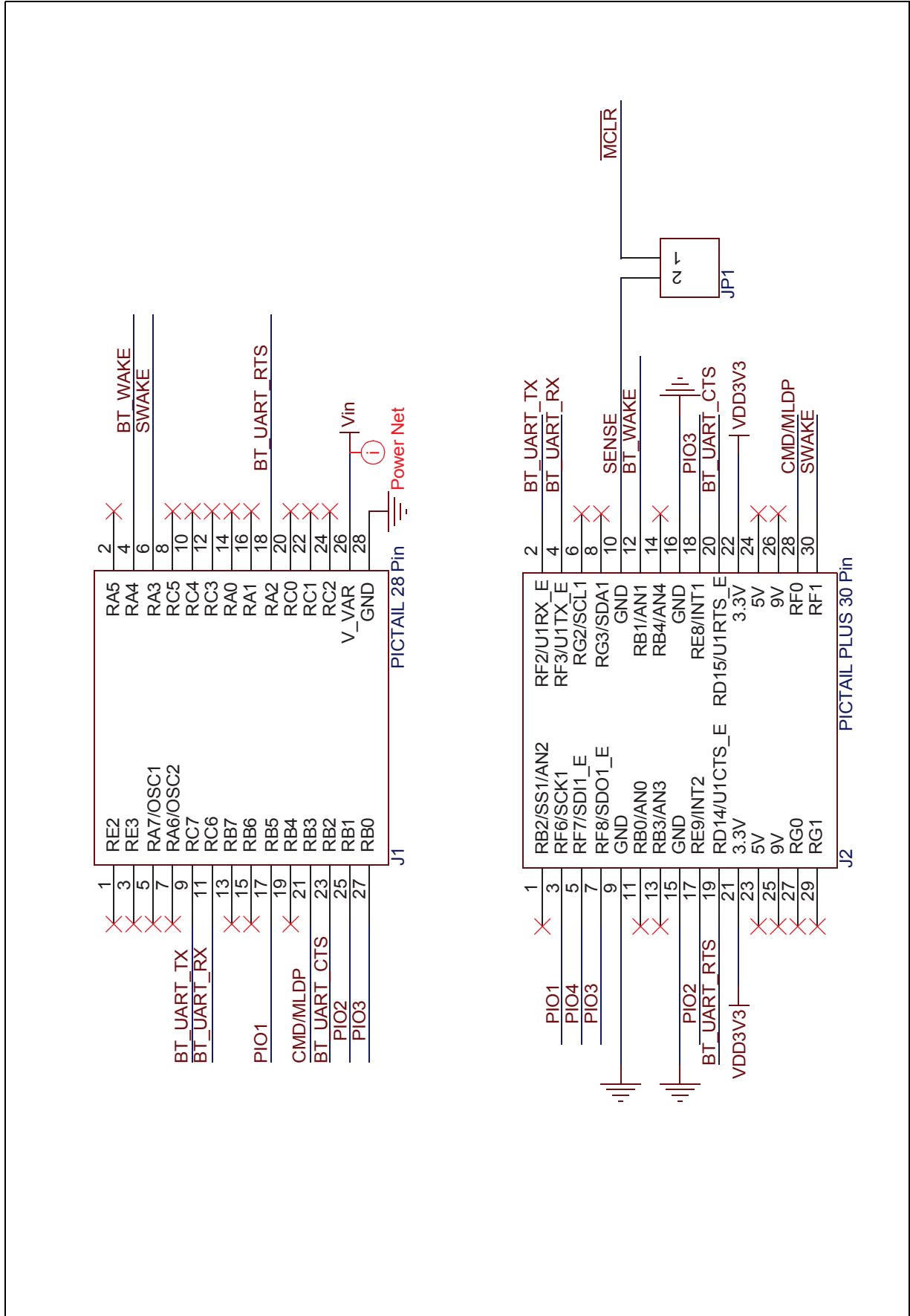

FIGURE A-3: 28-PIN AND 30-PIN PICTail™ CONNECTORS



RN4020 Bluetooth Low Energy Module User's Guide

FIGURE A-4: RN4020 MODULE BREAKOUT PINS

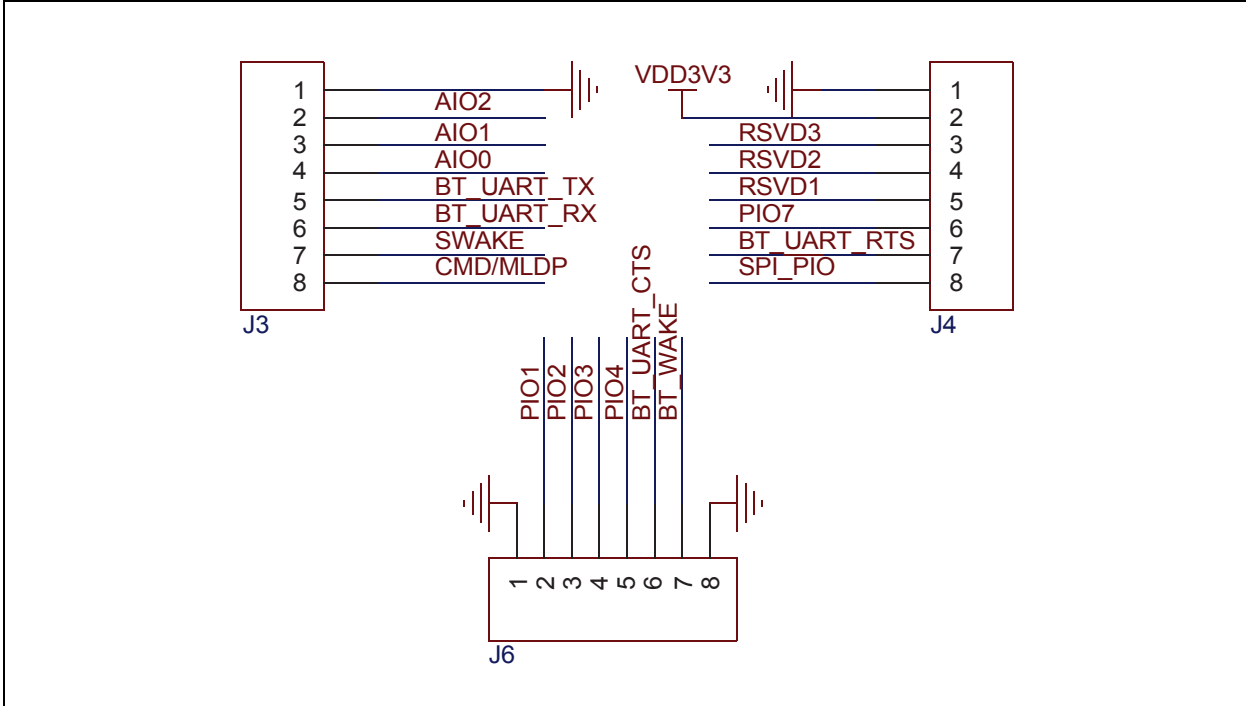

FIGURE A-5: STATUS LEDs

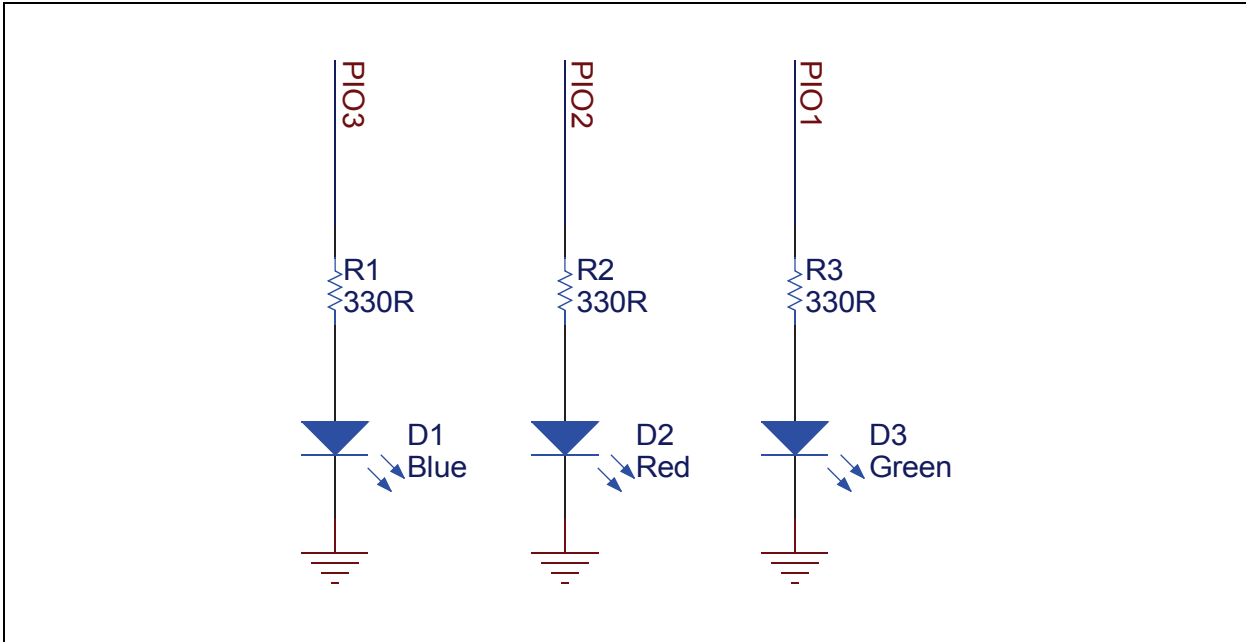

FIGURE A-6: VOLTAGE REGULATOR

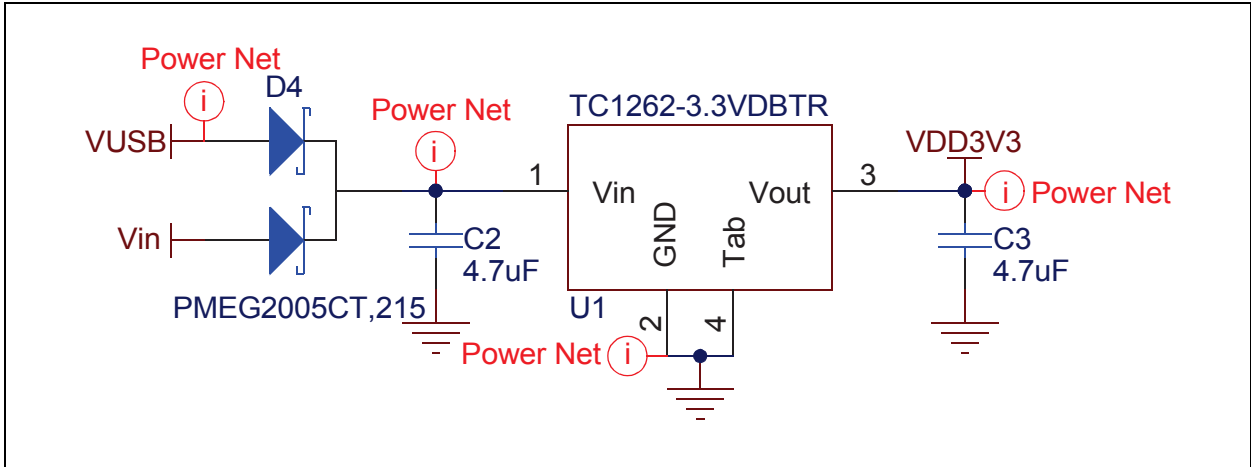

FIGURE A-7: DECOUPLING CAPACITOR FOR THE PIC18LF25K50-I/ML DEVICE

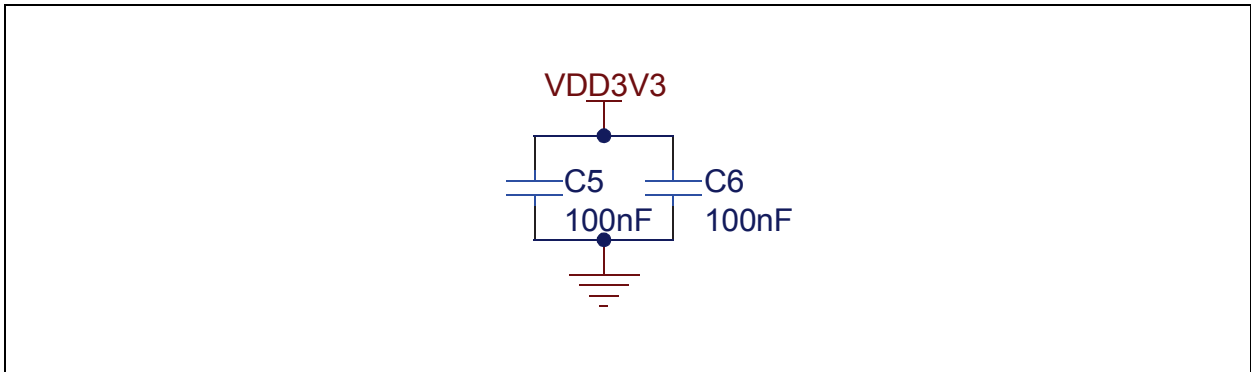

FIGURE A-8: TEST SWITCH

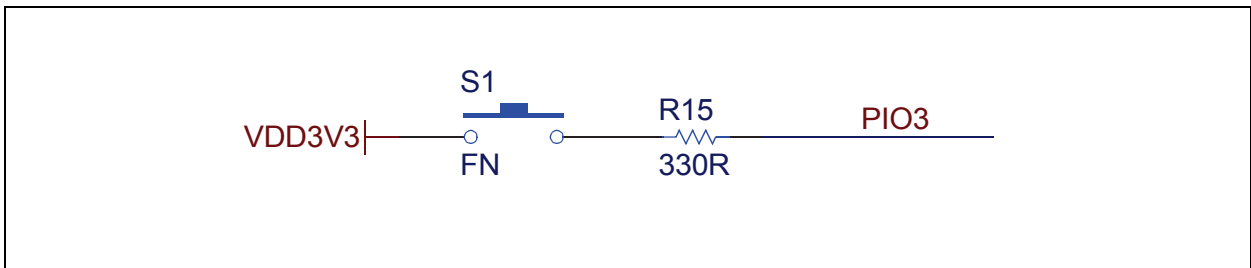
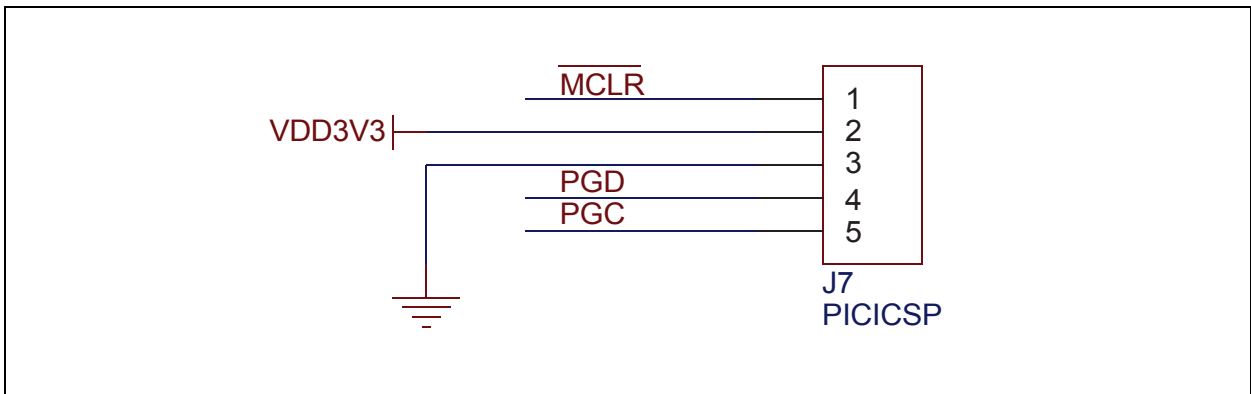

FIGURE A-9: ICSP™ CONNECTOR



RN4020 Bluetooth Low Energy Module User's Guide

NOTES:

NOTES:



MICROCHIP

Worldwide Sales and Service

AMERICAS

Corporate Office
2355 West Chandler Blvd.
Chandler, AZ 85224-6199
Tel: 480-792-7200
Fax: 480-792-7277
Technical Support:
<http://www.microchip.com/support>
Web Address:
www.microchip.com

Atlanta
Duluth, GA
Tel: 678-957-9614
Fax: 678-957-1455

Austin, TX
Tel: 512-257-3370

Boston
Westborough, MA
Tel: 774-760-0087
Fax: 774-760-0088

Chicago
Itasca, IL
Tel: 630-285-0071
Fax: 630-285-0075

Cleveland
Independence, OH
Tel: 216-447-0464
Fax: 216-447-0643

Dallas
Addison, TX
Tel: 972-818-7423
Fax: 972-818-2924

Detroit
Novi, MI
Tel: 248-848-4000

Houston, TX
Tel: 281-894-5983

Indianapolis
Noblesville, IN
Tel: 317-773-8323
Fax: 317-773-5453

Los Angeles
Mission Viejo, CA
Tel: 949-462-9523
Fax: 949-462-9608

New York, NY
Tel: 631-435-6000

San Jose, CA
Tel: 408-735-9110

Canada - Toronto
Tel: 905-673-0699
Fax: 905-673-6509

ASIA/PACIFIC

Asia Pacific Office
Suites 3707-14, 37th Floor
Tower 6, The Gateway
Harbour City, Kowloon
Hong Kong
Tel: 852-2943-5100
Fax: 852-2401-3431

Australia - Sydney
Tel: 61-2-9868-6733
Fax: 61-2-9868-6755

China - Beijing
Tel: 86-10-8569-7000
Fax: 86-10-8528-2104

China - Chengdu
Tel: 86-28-8665-5511
Fax: 86-28-8665-7889

China - Chongqing
Tel: 86-23-8980-9588
Fax: 86-23-8980-9500

China - Hangzhou
Tel: 86-571-8792-8115
Fax: 86-571-8792-8116

China - Hong Kong SAR
Tel: 852-2943-5100
Fax: 852-2401-3431

China - Nanjing
Tel: 86-25-8473-2460
Fax: 86-25-8473-2470

China - Qingdao
Tel: 86-532-8502-7355
Fax: 86-532-8502-7205

China - Shanghai
Tel: 86-21-5407-5533
Fax: 86-21-5407-5066

China - Shenyang
Tel: 86-24-2334-2829
Fax: 86-24-2334-2393

China - Shenzhen
Tel: 86-755-8864-2200
Fax: 86-755-8203-1760

China - Wuhan
Tel: 86-27-5980-5300
Fax: 86-27-5980-5118

China - Xian
Tel: 86-29-8833-7252
Fax: 86-29-8833-7256

China - Xiamen
Tel: 86-592-2388138
Fax: 86-592-2388130

China - Zhuhai
Tel: 86-756-3210040
Fax: 86-756-3210049

ASIA/PACIFIC

India - Bangalore
Tel: 91-80-3090-4444
Fax: 91-80-3090-4123

India - New Delhi
Tel: 91-11-4160-8631
Fax: 91-11-4160-8632

India - Pune
Tel: 91-20-3019-1500

Japan - Osaka
Tel: 81-6-6152-7160
Fax: 81-6-6152-9310

Japan - Tokyo
Tel: 81-3-6880-3770
Fax: 81-3-6880-3771

Korea - Daegu
Tel: 82-53-744-4301
Fax: 82-53-744-4302

Korea - Seoul
Tel: 82-2-554-7200
Fax: 82-2-558-5932 or
82-2-558-5934

Malaysia - Kuala Lumpur
Tel: 60-3-6201-9857
Fax: 60-3-6201-9859

Malaysia - Penang
Tel: 60-4-227-8870
Fax: 60-4-227-4068

Philippines - Manila
Tel: 63-2-634-9065
Fax: 63-2-634-9069

Singapore
Tel: 65-6334-8870
Fax: 65-6334-8850

Taiwan - Hsin Chu
Tel: 886-3-5778-366
Fax: 886-3-5770-955

Taiwan - Kaohsiung
Tel: 886-7-213-7830

Taiwan - Taipei
Tel: 886-2-2508-8600
Fax: 886-2-2508-0102

Thailand - Bangkok
Tel: 66-2-694-1351
Fax: 66-2-694-1350

EUROPE

Austria - Wels
Tel: 43-7242-2244-39
Fax: 43-7242-2244-393

Denmark - Copenhagen
Tel: 45-4450-2828
Fax: 45-4485-2829

France - Paris
Tel: 33-1-69-53-63-20
Fax: 33-1-69-30-90-79

Germany - Dusseldorf
Tel: 49-2129-3766400

Germany - Munich
Tel: 49-89-627-144-0
Fax: 49-89-627-144-44

Germany - Pforzheim
Tel: 49-7231-424750

Italy - Milan
Tel: 39-0331-742611
Fax: 39-0331-466781

Italy - Venice
Tel: 39-049-7625286

Netherlands - Drunen
Tel: 31-416-690399
Fax: 31-416-690340

Poland - Warsaw
Tel: 48-22-3325737

Spain - Madrid
Tel: 34-91-708-08-90
Fax: 34-91-708-08-91

Sweden - Stockholm
Tel: 46-8-5090-4654

UK - Wokingham
Tel: 44-118-921-5800
Fax: 44-118-921-5820

03/25/14